

**ELECTROTECHNOLOGICAL SYSTEM FOR MONITORING EFFECTS OF OPTICAL RANGE
ELECTROMAGNETIC FIELDS ON VEGETATION BIOOBJECT**

L.Nikiforova, I.Kizim, Yu.Bogatyrev
Tavria State Agrotechnological University,
18, B.Khmelnitsky Avenue, Melitopol, Zaporizhia obl., 72310, Ukraine
E-mail: etapk@yandex.ru

The question of application of sources of light on light-emitting diodes in hothouses is considered. The necessity of development of complex for registration of bioelectric potentials of plants, necessity for working off technology of growing of plants with the use of lamps on light-emitting diodes is grounded. The developed measuring complex allows to influence on vegetable bioobjects with LED (laser) SOR and to estimate the response in real time. Size of BEP reflects real processes of a metabolism and is inseparably linked with a physiological condition of a live organism, and the steady nonequilibrium state in vegetable organisms is supported due to processes of a metabolism continuously proceeding in them. Thus, at research of various ways of stimulation of development of VBO measurement of size BEP can be used for an assessment of a functional condition of VBO at different stages of an organogenesis. References 3, figures 2.

Key words: vegetable bioobject, bioelectronic potential, diagnostics, LED (laser) light source.

Statement of the problem. Modern development in semiconductor branch allows to make inexpensive highly effective LED and laser sources of optical radiation (SOR), that are differing in high light return and big service life. Big advantage of light-emitting diode and laser sources of optical radiation is possibility of obtaining monochromatic radiation practically in any part of a range. Advantage of laser sources of optical radiation is coherence of radiation. Semiconductor sources of optical radiation are applied more actively in plants of the closed soil, that is caused not only by obtaining monochromatic radiation in phytoactive part of a range, but also by low power consumption and low thermal emission, that gives the chance to establish light-emitting diodes (laser diodes) near vegetable bioobjects (VBO) without risk of their damage.

Modern light-emitting diodes (laser diodes) use all visible range of an optical spectrum. Range radiation waves lengths of semiconductor sources of optical radiation in red area of a spectrum is 620-780 nm, in orange – 600-620 nm, in yellow – 585-595 nm, in green – 500-570 nm, in pale blue – 465-490 nm and in dark blue – 430-465 nm. Thus, making combinations of light-emitting diodes (laser diodes) of different range of radiation, it is possible to receive a source of optical radiation with almost any spectral structure in the visible range.

Spectral maxima of absorption of a chlorophyll "a" vegetable bioobject coincide with 410,2; 430,8 and 656,3 nm lines; red maxima of a chlorophyll "b" coincide with 640 and 649,5 nm lines; phytochrome – with 381,6; 396,8 and 656,3 nm lines. The greatest quantity of maxima of absorption of functionally different pigments the strip with width 390-440 nanometers possesses. The green range isn't absolutely necessary for ensuring photosynthesis, but thanks to the high penetration is useful to ensuring photosynthesis optically dense leaves and dense crops of vegetable bioobjects [2]. Therefore in a LED (laser) source some colors can be combined, that block these phytoactive sites. However, the question of an optimum combination of light-emitting diodes (laser diodes) of certain range of radiation isn't solved yet, and there is a set of recommendations about this occasion, differing from each other.

Analysis of recent research. At present producers of LED production offered a wide choice of the LED phytolamps, differing by the power, a percentage ratio of applied light-emitting diodes of a certain range and, respectively, the general range of radiation. According to results of researches [3] the optimum structure of radiation has the following ratio of energy on a range: 30% – dark blue spectrum, 20% – green spectrum, 50% – red spectrum. However, light-emitting diodes of a green range in industrial samples of phytolamps practically aren't applied. The relation of a light stream of red and dark blue light in the majority of the LED lamps calculated on ensuring good photosynthesis of plants during various period of their growth, varies in the wide range: 9:5, 6:3, 11:5, 7:1, 8:1 and 9:1. In the same time not enough attention is paid by producers of phytolamps to coherent SOR – lasers though they found a wide circulation for example in preseedling processing.

The formulation of article purposes. For definition of an optimum ratio of quantity of light-emitting diodes (laser diodes) a different range, of influence of coherence of radiation on activity of vegetable bioobjects, for research of influence of operating modes of LED (laser) SOR on them, and also for the purpose of providing the best conditions for receiving ready for goods, it is necessary to develop a technique and the measuring complex, that allow LED (laser) SOR to influence on vegetable bioobjects and allow to estimate response in real time.

The main part. The majority of the experiments, that are made for the purpose of studying of influence on VBO of these or those factors, are estimated by results of end products (viability, energy of germination, productivity) which can't be connected unambiguously with their influence that demands additional eliminating experiments and that is extremely inefficient from the power and temporary point of view. The optimum decision is the analysis of instant

reaction of VBO on external influence. For a small period it is difficult to observe direct reaction of vegetable bioobjects to these influences, however it is possible to fix the bioelectric potential (BEP) of cells.

Bioelectric polarity of VBO is expressed in distinctions of metabolic potentials between separate bodies, tissues, cells in a stable permanent state. Size of BEP reflects real processes of a metabolism and is inseparably linked with a physiological condition of a live organism, and the steady nonequilibrium state in vegetable organisms is supported due to processes of a metabolism continuously proceeding in them. Thus, at research of various ways of stimulation of development of VBO measurement of size BEP can be used for an assessment of a functional condition of VBO at different stages of an organogenesis.

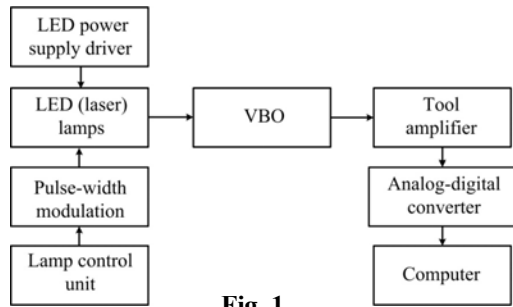

Fig. 1

Pulse bioelectric activity characterizes changes in functional activity of vegetable bioobjects and that activity is the answer to changes in environment and answer on influences of irritating factors. Pulse electric activity divides on three types: the action potentials (AP) - pulse electric answers to supraliminal stimulus; the variable potentials which are reaction of the highest VBO on damaging, or high-energy influences; microrhythms is a type of rhythmic pulse electric activity in VBO [1].

Active capacity of big group of cells (vegetable tissue) can be measured by contact of electrodes with different points of VBO, where the bioelectricity is measured. In this case the observed signal occurs because of cellular polarization-depolarization.

Now complexes for measurement of electric activity of VBO aren't made. The devices developed by efforts of certain researchers, are difficult in operation and demand special conditions and high qualification of the personnel.

Existence of such complex for measurement of BEP of vegetable bioobjects will allow studying the interrelation characteristic "the radiation system – object of radiation" and will give the chance to fulfill technology of cultivation of VBO with application of LED (laser) SOR that in its turn will allow to increase growth of ready goods and to reduce energy consumption.

For studying of influence of LED (laser) SOR on VBO development of the complex including lighting installa-

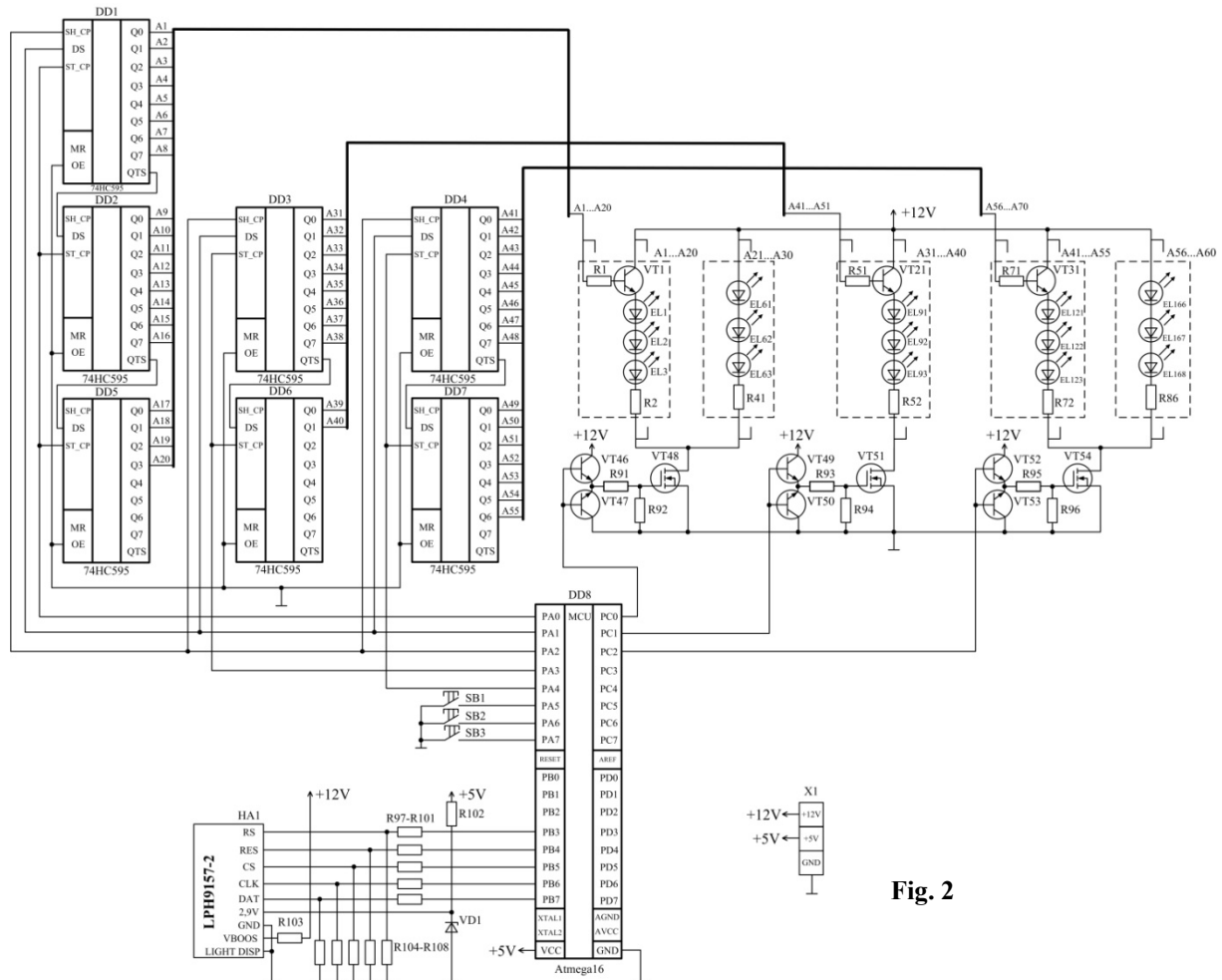

Fig. 2

tion on ultrabright light-emitting diodes of green, blue and red ranges of radiation (or the block of laser diodes of the corresponding range), the block of registration of BEP and the computer that is intended for collecting, displaying and the analyzing of received information is supposed (fig. 1).

By means of the control unit and the pulse-width modulation it can be carried out both regulation of intensity of the general optical stream and change of spectral structure due to adjustment of intensity of radiation of light-emitting diodes (laser diodes) in various color ranges, than influence on MBO is provided (fig. 2). Also, the spectral structure can be changed and in the discrete way, changing quantity of SOR of the certain range participating in process of radiation that gives the chance to define their exact ratio.

BEP of vegetable bioobject arrives on an entrance of the tool amplifier, further on an entrance of the block of the analog-digital converter after what the digital signal arrives on the computer for further processing and the analysis of influence of operating modes and spectral structure of radiation of LED (laser) SOR on vegetable bioobjects.

Conclusions. The creation of electrotechnological system of control on influence of electromagnetic fields of optical range on vegetable bioobjects will allow:

– to define an optimal range and power of optical radiation of semiconductor sources at their influence on vegetable bioobjects at different stages of development;

– to develop power effective, ecologically safe agrotechnology of processing vegetable bioobjects electromagnetic fields of optical range reaction considering them to radiation with the subsequent regulation of its range and power.

1. Kogan A.B. Electrophysiology. – Moskva: Vysshaya shkola, 1969. – 368 p. (Rus)

2. The reference book on light engineering. – Moskva: Znack, 2006. – 972 p. (Rus)

3. Prokofev A., Turkin A., Jakovlev A. Prospects of LED applications in plant growing // Poluprovodnikovaia Svetotekhnika. – 2010. – N5. – Pp. 60–63. (Rus)

УДК 631.17

ЭЛЕКТРОТЕХНОЛОГИЧЕСКАЯ СИСТЕМА ДЛЯ КОНТРОЛЯ ВЛИЯНИЯ ЭЛЕКТРОМАГНИТНЫХ ПОЛЕЙ ОПТИЧЕСКОГО ДИАПАЗОНА НА РАСТИТЕЛЬНЫЕ БИООБЪЕКТЫ

Никифорова Л.Е., докт.техн.наук, **Кизим И.В., Богатырев Ю.О.**

**Таврический государственный агротехнологический университет,
пр. Б.Хмельницкого, 18, Мелитополь, 72312, Украина.**

e-mail: etapk@yandex.ru

Рассмотрен вопрос использования полупроводниковых светодиодных и лазерных источников оптического излучения (ИОИ) в условиях закрытого грунта. Обоснована структура электротехнологического комплекса контроля влияния электромагнитных полей оптического диапазона на растительные биообъекты путем регистрации биопотенциалов растений. Разработанный измерительный комплекс позволяет влиять на растительные биообъекты (РБО) светодиодными (лазерными) ИОИ и оценивать ответную реакцию в режиме реального времени. Величина биоэлектрического потенциала (БЭП) отражает реальные процессы обмена веществ и неразрывно связана с физиологическим состоянием живого организма, а устойчивое неравновесное состояние в растительных организмах поддерживается за счет непрерывно протекающих в них процессов обмена веществ. Таким образом, при исследовании различных способов стимулирования развития РБО измерение величины БЭП может использоваться для оценки функционального состояния РБО на разных стадиях органогенеза. Библ. 3, рис. 2.

Ключевые слова: растительный биообъект, биоэлектрический потенциал, диагностика, светодиодный (лазерный) источник света.

УДК 631.17

ЕЛЕКТРОТЕХНОЛОГІЧНА СИСТЕМА ДЛЯ КОНТРОЛЮ ВПЛИВУ ЕЛЕКТРОМАГНІТНИХ ПОЛІВ ОПТИЧНОГО ДІАПАЗОНУ НА РОСЛИННІ БІООБ'ЄКТИ

Никифорова Л.Є., докт.техн.наук, **Кізім І.В., Богатирьов Ю.О.**

**Таврійський державний агротехнологічний університет,
пр. Б.Хмельницького, 18, Мелітополь, 72312, Україна.**

e-mail: etapk@yandex.ru

Розглянуто питання використання напівпровідникових світлодіодних і лазерних джерел оптичного випромінювання (ДОВ) в умовах захищеного ґрунту. Обґрунтована структура електротехнологічного комплексу контролю впливу електромагнітних полів оптичного діапазону на рослинні біооб'єкти (РБО) шляхом реєстрації біопотенціалів рослин. Розроблений вимірювальний комплекс дозволяє впливати на рослинні біооб'єкти світлодіодними (лазерними) ДОВ і оцінювати реакцію у відповідь в режимі реального часу. Величина біоелектричного потенціалу (БЕП) відображає реальні процеси обміну речовин і нерозривно пов'язана з фізіологічним станом живого організму, а стійкий нерівноважний стан в рослинних організмах підтримується за рахунок безперервно протікаючих в них процесів обміну речовин. Таким чином, при дослідженні різних способів стимулювання розвитку РБО вимірювання величини БЕП може використовуватися для оцінки функціонального стану РБО на різних стадіях органогенезу. Бібл. 3, рис. 2.

Ключові слова: рослинний біооб'єкт, біоелектричний потенціал, діагностика, світлодіодне (лазерне) джерело світла.

Надійшла 30.01.2014