

THE UNBALANCE POWER IDENTIFICATION IN THE THREE-PHASE FOUR-WIRE POWER SUPPLY SYSTEM FOR THE NEEDS OF ITS DISTRIBUTED COMPENSATION

M.Yu. Artemenko^{1*}, V.V. Chopyk^{2**}, V.M. Mikhalsky^{2***}, I.A. Shapoval^{2****}, S.Y. Polishchuk^{2*****}

¹ National Technical University of Ukraine "Igor Sikorsky Kyiv Polytechnic Institute",

Peremohy ave., 37, Kyiv, 03056, Ukraine,

² Institute of Electrodynamics of the National Academy of Sciences of Ukraine,

Peremohy ave., 56, Kyiv, 03057, Ukraine.

E-mail: mikhalsky@ied.org.ua

The idea of distributed active filtration is to compensate the currents of higher harmonics and undesirable power components of the main network with renewable energy converters of the connected microgrid, which have reserves of apparent power. For the convenience of distributed compensation, it is proposed to identify the sinusoidal mode of the three-phase four-wire power system, provided from the symmetric source by six mutually orthogonal components of the three-coordinate load current vector. The unbalance power is shown to be due to four mutually orthogonal components of load current vector with defined reference voltage vectors, each of which is proportional to a separate orthogonal component of the unbalance power. Integral formulas for determining the scalar values of the four specified orthogonal components of unbalance powers have been obtained, which open the possibility to account for their contribution to the deterioration of the power quality and synthesize the control signals for distributed active filtration. The connection between the four specified orthogonal components of the unbalance power and the linear asymmetric load parameters was established, making it possible to verify these integral formulas using a computer experiment. It is analytically established and experimentally confirmed that the squares of the two orthogonal components of the unbalance powers associated with the current of the neutral wire are included in the decompositions of the square of apparent power and power losses with the multiplier, depending on the ratio of the resistances of the transmission line of the three-phase four-wire power system. References 17, figures 3.

Keywords: unbalance power, microgrid, shunt active filter control strategy, distributed filtering.

Introduction. The need for more reliable and flexible power systems, combined with the great potential of modern control systems and power electronics, made it possible to create a new concept of electrical energy supply known today as a distributed generation (DG). In DG systems where a microgrid (MG) with renewable sources can operate autonomously and in the connection mode to the main network, the power quality problem comes to the fore. At the same time, without taking special measures, the MG acts as a non-stationary, nonlinear, and unbalanced load of the main network.

The load asymmetry of the three-phase power supply system leads to a deterioration in the quality of electrical energy, causing the unbalanced voltage at the points of common connection and additional power losses in the transmission line, which may exceed the losses caused by reactive power [1]. At the same time, the additional energy consumption of the supplier caused by the load asymmetry is not paid by the consumer. The quantitative measure of the unbalanced load is the unbalance power, the square of which the standard [2] defines as the difference between a square of apparent power and squares of active and reactive power. However, this definition does not specify practical methods for the compensation, measurement, and accounting of the unbalance power by hardware. In [3] the method of calculating the square of the unbalance power due to the value of active and reactive powers of individual phases is presented, which allows estimating the loss of electrical energy from asymmetry and reactivity of the load, but leaves open the problem of direct measurement and compensation of unbalance power. The most effective hardware compensating for inactive power components is semiconductor shunt active filters (SAF). SAF control strategies aimed at compensating for the unbalance power are based both on the Fortescue theory of

© Artemenko M.Yu., Chopik V.V., Mikhalsky V.M., Shapoval I.A., Polishchuk S.Y., 2022
 ORCID ID: *<https://orcid.org/0000-0001-9341-9238>; **<https://orcid.org/0000-0002-5046-5223>;
 <https://orcid.org/0000-0002-8251-3111>; *<https://orcid.org/0000-0002-9107-5061>;
 *****<https://orcid.org/0000-0002-6978-2747>

symmetric components [4], developed for this application, for example, in [5], and on several power theories [6-10], which in various ways associate the power of the unbalance with specific components of the load current vector. The most advanced for linear load and four-wire power system, this connection is visible within the Current Physical Component theory [11], where the unbalance power is associated with two components of the load current vector, proportional to the symmetric components of the negative and zero sequences. But the corresponding proportionality coefficients are determined due to the load complex conductivities of individual phases, which complicated the use of this theory for filtering the non-stationary and nonlinear load currents. Even though SAF are an effective means of compensating for inactive powers in microgrids connected to distribution networks, their installation as a separate device increases the total cost of ensuring the quality of electrical energy. To reduce the cost of microgrids, developers began to focus on the ideas of distributed active filtration, placing the functions of compensation for currents of higher harmonics and undesirable power components on inverters of renewable energy converters that have reserves of apparent power [12, 13]. In this regard, for the convenience of distributed compensation for the unbalance power, it is advisable to present it as many orthogonal components as possible, having separate contributions to the transmission line power losses and apparent power.

The article aims to develop a mathematical apparatus for identifying the unbalance power of a three-phase four-wire power supply system aimed at its direct measurement and accounting by technical means and compensation in the process of distributed filtration.

Main part. Figure 1 shows an example of a microgrid (MG) connected to the main power network, between which mutual exchange of electrical energy is possible. It consists of loads (e.g., household or production loads and charging of electric vehicle batteries), a photovoltaic generating (PVG) system, a wind generating (WG) system, and an electrical energy storage system. Control of the microgrid is carried out by a control system, which should provide regulated power quality indicators at points of common coupling (PCC). Each of the renewable sources and storages of electrical energy has an embedded semiconductor converter, which performs the function of an energy interface with a microgrid and is controlled by a control system. The main idea of distributed filtration is to compensate for all inactive components of the load current, mainly with embedded semiconductor converters, as a result of which the shunt active filter loading decreases. The problem arises to establish the particle of inactive power that falls on each converter and its identification in the form of compensation currents.

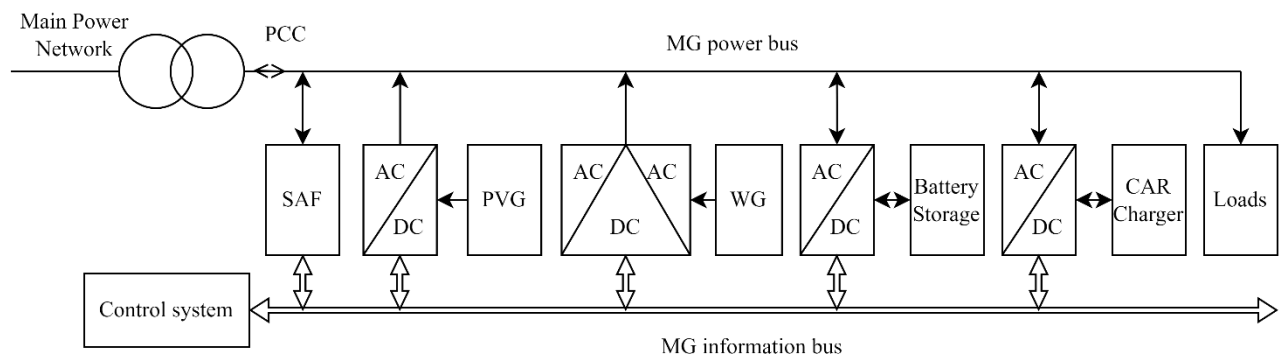

Fig. 1

The stationary energy process in the three-phase four-wire power supply system under symmetric sinusoidal source and nonlinear load is fully determined by the three-coordinate vectors of phase voltages and line currents represented in the time domain.

$$\mathbf{u}(t) = \begin{Bmatrix} u_A(t) \\ u_B(t) \\ u_C(t) \end{Bmatrix} = \sqrt{2} \begin{Bmatrix} U_\phi \cos(\omega t) \\ U_\phi \cos(\omega t - 2\pi/3) \\ U_\phi \cos(\omega t + 2\pi/3) \end{Bmatrix}; \mathbf{i}(t) = \begin{Bmatrix} i_A(t) \\ i_B(t) \\ i_C(t) \end{Bmatrix} = \sqrt{2} \begin{Bmatrix} I_A \cos(\omega t + \psi_A) \\ I_B \cos(\omega t + \psi_B) \\ I_C \cos(\omega t + \psi_C) \end{Bmatrix} + \mathbf{i}_H(t), \quad (1)$$

where U_ϕ is the RMS value of phase voltages, $\omega=2\pi/T$ is the cyclic voltage frequency of a three-phase source; I_A, I_B, I_C are the RMS values of the first harmonic currents of the corresponding line wires, ψ_A, ψ_B, ψ_C are their initial phases, $\mathbf{i}_H(t)$ is the vector of currents of higher harmonics. Let's present these vectors as the first members of the Fourier series in a complex form and arrange them according to the unit vectors of

symmetrical components of the positive, negative, and zero phase sequences:

$$\begin{aligned}\bar{\mathbf{u}} &= \frac{1}{T} \int_T \mathbf{u}(t) e^{-j\omega t} dt = \begin{vmatrix} \dot{U}_A \\ \dot{U}_B \\ \dot{U}_C \end{vmatrix} = U_\phi \begin{vmatrix} 1 \\ e^{-j2\pi/3} \\ e^{j2\pi/3} \end{vmatrix} = \frac{U_\pi}{\sqrt{3}} \begin{vmatrix} 1 \\ \tilde{a} \\ \tilde{a} \end{vmatrix} = U_\pi \bar{\mathbf{e}}_+; \\ \bar{\mathbf{i}} &= \frac{1}{T} \int_T \mathbf{i}(t) e^{-j\omega t} dt = \begin{vmatrix} \dot{I}_A \\ \dot{I}_B \\ \dot{I}_C \end{vmatrix} = \begin{vmatrix} I_A e^{j\psi_A} \\ I_B e^{j\psi_B} \\ I_C e^{j\psi_C} \end{vmatrix} = \frac{\dot{I}_+}{\sqrt{3}} \begin{vmatrix} 1 \\ \tilde{a} \\ \tilde{a} \end{vmatrix} + \frac{\dot{I}_-}{\sqrt{3}} \begin{vmatrix} 1 \\ \tilde{a} \\ \tilde{a} \end{vmatrix} + \frac{\dot{I}_0}{\sqrt{3}} \begin{vmatrix} 1 \\ 1 \\ 1 \end{vmatrix} = \dot{I}_+ \bar{\mathbf{e}}_+ + \dot{I}_- \bar{\mathbf{e}}_- + \dot{I}_0 \bar{\mathbf{e}}_0,\end{aligned}\quad (2)$$

where $U_\pi = U_\phi \sqrt{3}$ is the RMS value of the line voltage; $\dot{a} = e^{j2\pi/3}$; $\tilde{a} = e^{-j2\pi/3}$; $\bar{\mathbf{e}}_+$ is the unit vector of positive sequence; $\bar{\mathbf{e}}_- = \begin{vmatrix} 1 \\ \tilde{a} \\ \tilde{a} \end{vmatrix} / \sqrt{3} = \bar{\mathbf{e}}_+^*$; $\bar{\mathbf{e}}_0 = \begin{vmatrix} 1 \\ 1 \\ 1 \end{vmatrix} / \sqrt{3}$ are unit vectors of negative and zero sequences; $\wedge, *$ are transpose and complex conjugation symbols; $\dot{I}_+ = I_{R+} + jI_{I+}$; $\dot{I}_- = I_{R-} + jI_{I-}$; $\dot{I}_0 = I_{R0} + jI_{I0}$ are complex coefficients, depending on the coordinates of the complex vector $\bar{\mathbf{i}}$. To clarify the physical content of these coefficients, we introduce mutually orthogonal complex voltage vectors proportional to the unit vectors of symmetric components:

$$\bar{\mathbf{u}}_+ = \bar{\mathbf{u}} = \begin{vmatrix} \dot{U}_A \\ \dot{U}_B \\ \dot{U}_C \end{vmatrix} = \frac{U_\pi}{\sqrt{3}} \begin{vmatrix} 1 \\ \tilde{a} \\ \tilde{a} \end{vmatrix} = U_\pi \bar{\mathbf{e}}_+; \bar{\mathbf{u}}_- = U_\pi \bar{\mathbf{e}}_- = \frac{U_\pi}{\sqrt{3}} \begin{vmatrix} 1 \\ \tilde{a} \\ \tilde{a} \end{vmatrix} = \begin{vmatrix} \dot{U}_A \\ \dot{U}_C \\ \dot{U}_B \end{vmatrix}; \bar{\mathbf{u}}_0 = U_\pi \bar{\mathbf{e}}_0 = \frac{U_\pi}{\sqrt{3}} \begin{vmatrix} 1 \\ 1 \\ 1 \end{vmatrix} = \begin{vmatrix} \dot{U}_A \\ \dot{U}_A \\ \dot{U}_A \end{vmatrix},$$

then the three-coordinate vector of linear currents (2) allows such decomposition into the entered voltage vectors:

$$\bar{\mathbf{i}} = \begin{vmatrix} I_A e^{j\psi_A} \\ I_B e^{j\psi_B} \\ I_C e^{j\psi_C} \end{vmatrix} = (\dot{I}_+ \bar{\mathbf{u}}_+ + \dot{I}_- \bar{\mathbf{u}}_- + \dot{I}_0 \bar{\mathbf{u}}_0) U_\pi^{-1}. \quad (3)$$

Complex scalar coefficients of expression (3) are found as scalar products of the line current vector and corresponding mutually orthogonal complex voltage vectors:

$$\begin{aligned}U_\pi \dot{I}_+ &= U_\pi (I_{R+} + jI_{I+}) = \bar{\mathbf{i}} \wedge \bar{\mathbf{u}}_+^* = P - jQ; I_{R+} = P / U_\pi; I_{I+} = -Q / U_\pi; \\ U_\pi \dot{I}_- &= U_\pi (I_{R-} + jI_{I-}) = \bar{\mathbf{i}} \wedge \bar{\mathbf{u}}_-^* = D_R - jD_I; I_{R-} = D_R / U_\pi; I_{I-} = -D_I / U_\pi; \\ U_\pi \dot{I}_0 &= U_\pi (I_{R0} + jI_{I0}) = \bar{\mathbf{i}} \wedge \bar{\mathbf{u}}_0^* = N_R - jN_I; I_{R0} = N_R / U_\pi; I_{I0} = -N_I / U_\pi,\end{aligned}\quad (4)$$

where P, Q are active and reactive power; D_R, D_I are scalar coefficients of orthogonal components of the unbalance power associated with the vector of symmetric voltages of the negative sequence, in the future, simply the unbalance power of the negative sequence; N_R, N_I are scalar coefficients of the orthogonal components of the power of the unbalance associated with the symmetric voltage vector of the zero sequence, in the future simply the unbalance power of the zero sequence. We substitute the obtained scalar powers in (3) and form six corresponding reference voltage vectors:

$$\begin{aligned}\bar{\mathbf{i}} &= \begin{vmatrix} \dot{I}_A \\ \dot{I}_B \\ \dot{I}_C \end{vmatrix} = \frac{P - jQ}{U_\pi U_\phi \sqrt{3}} \begin{vmatrix} \dot{U}_A \\ \dot{U}_B \\ \dot{U}_C \end{vmatrix} + \frac{D_R - jD_I}{U_\pi U_\phi \sqrt{3}} \begin{vmatrix} \dot{U}_A \\ \dot{U}_C \\ \dot{U}_B \end{vmatrix} + \frac{N_R - jN_I}{U_\pi U_\phi \sqrt{3}} \begin{vmatrix} \dot{U}_A \\ \dot{U}_A \\ \dot{U}_A \end{vmatrix} = \\ &= \frac{P}{U_\pi^2} \begin{vmatrix} \dot{U}_A \\ \dot{U}_B \\ \dot{U}_C \end{vmatrix} + \frac{Q}{U_\pi^2} \begin{vmatrix} -j\dot{U}_A \\ -j\dot{U}_B \\ -j\dot{U}_C \end{vmatrix} + \frac{D_R}{U_\pi^2} \begin{vmatrix} \dot{U}_A \\ \dot{U}_C \\ \dot{U}_B \end{vmatrix} + \frac{D_I}{U_\pi^2} \begin{vmatrix} -j\dot{U}_A \\ -j\dot{U}_C \\ -j\dot{U}_B \end{vmatrix} + \frac{N_R}{U_\pi^2} \begin{vmatrix} \dot{U}_A \\ \dot{U}_A \\ \dot{U}_A \end{vmatrix} + \frac{N_I}{U_\pi^2} \begin{vmatrix} -j\dot{U}_A \\ -j\dot{U}_A \\ -j\dot{U}_A \end{vmatrix}.\end{aligned}$$

It is easy to ensure that all six resulting complex support voltage vectors of current components are mutually orthogonal. We express them through the existing phase and line complex voltages of a three-phase source, then the decomposition of the first harmonics of the line current vector in the frequency domain takes the form of

$$\begin{aligned} \bar{\mathbf{i}} &= \frac{P}{U_{JI}^2} \begin{bmatrix} \dot{U}_A \\ \dot{U}_B \\ \dot{U}_C \end{bmatrix} + \frac{Q}{U_{JI}^2 \sqrt{3}} \begin{bmatrix} \dot{U}_{BC} \\ \dot{U}_{CA} \\ \dot{U}_{AB} \end{bmatrix} + \frac{D_R}{U_{JI}^2} \begin{bmatrix} \dot{U}_A \\ \dot{U}_B \\ \dot{U}_C \end{bmatrix} + \frac{D_I}{U_{JI}^2 \sqrt{3}} \begin{bmatrix} \dot{U}_{BC} \\ \dot{U}_{AB} \\ \dot{U}_{CA} \end{bmatrix} + \frac{N_R}{U_{JI}^2} \begin{bmatrix} \dot{U}_A \\ \dot{U}_B \\ \dot{U}_C \end{bmatrix} + \frac{N_I}{U_{JI}^2 \sqrt{3}} \begin{bmatrix} \dot{U}_{BC} \\ \dot{U}_{CA} \\ \dot{U}_{AB} \end{bmatrix} = \\ &= (P\bar{\mathbf{u}}_P + Q\bar{\mathbf{u}}_Q + D_R\bar{\mathbf{u}}_{DR} + D_I\bar{\mathbf{u}}_{DI} + N_R\bar{\mathbf{u}}_{NR} + N_I\bar{\mathbf{u}}_{NI})U_{JI}^{-2} = \bar{\mathbf{i}}_P + \bar{\mathbf{i}}_Q + \bar{\mathbf{i}}_{DR} + \bar{\mathbf{i}}_{DI} + \bar{\mathbf{i}}_{NR} + \bar{\mathbf{i}}_{NI}. \end{aligned} \quad (5)$$

Each of the scalar powers of decomposition (5) can be found as a scalar product of the current vector and the corresponding reference voltage vector and measured by a wattmeter. In particular, the calculation formulas of active and reactive power:

$$\begin{aligned} P &= \text{Re}(\bar{\mathbf{i}} \wedge \bar{\mathbf{u}}_P^*) = \text{Re}(\dot{I}_A \dot{U}_A^* + \dot{I}_B \dot{U}_B^* + \dot{I}_C \dot{U}_C^*) = \int_T (u_A i_A + u_B i_B + u_C i_C) dt; \\ Q &= \text{Re}(\bar{\mathbf{i}} \wedge \bar{\mathbf{u}}_Q^*) = \text{Re}(\dot{I}_A \dot{U}_{BC}^* + \dot{I}_B \dot{U}_{CA}^* + \dot{I}_C \dot{U}_{AB}^*) / \sqrt{3} = \int_T (u_{BC} i_A + u_{CA} i_B + u_{AB} i_C) dt / \sqrt{3} \end{aligned} \quad (6)$$

correspond to known measurement methods using three wattmeters to determine each power [14]. The scalar unbalance powers of the negative sequence are calculated as follows:

$$\begin{aligned} D_R &= \text{Re}(\bar{\mathbf{i}} \wedge \bar{\mathbf{u}}_{DR}^*) = \int_T (u_A i_A + u_C i_B + u_B i_C) dt = W_{AN,A} + W_{CN,B} + W_{BN,C}; \\ D_I &= \text{Re}(\bar{\mathbf{i}} \wedge \bar{\mathbf{u}}_{DI}^*) = \int_T (u_{BC} i_A + u_{AB} i_B + u_{CA} i_C) dt / \sqrt{3} = (W_{BC,A} + W_{AB,B} + W_{CA,C}) / \sqrt{3}, \end{aligned} \quad (7)$$

which correspond to the measurement schemes consisting of three wattmeters for each power (Fig. 2). Suppose six wattmeters are already used to measure active and reactive powers in accordance with (6). In that case, measuring the unbalance powers will also require 4 wattmeters, since the readings of $W_{AN,A}$ and $W_{BC,A}$ are already known. Let us determine the integral unbalance powers of the zero-sequence

$$\begin{aligned} N_I &= \text{Re}(\bar{\mathbf{i}} \wedge \bar{\mathbf{u}}_{NI}^*) = \int_T (u_A i_A + u_A i_B + u_A i_C) dt = \int_T u_A (i_A + i_B + i_C) dt = \int_T u_A i_N dt = W_{AN,N}; \\ N_R &= \text{Re}(\bar{\mathbf{i}} \wedge \bar{\mathbf{u}}_{NR}^*) = \int_T (u_{BC} i_A + u_{BC} i_B + u_{BC} i_C) dt / \sqrt{3} = \int_T u_{BC} i_N dt / \sqrt{3} = W_{BC,N} / \sqrt{3}. \end{aligned} \quad (8)$$

From (8), it follows that these components of the unbalance power are due to the non-zero neutral current, so to measure them, it is enough to add one wattmeter to the measuring circuits in Fig. 2, including their current windings in the gap of the neutral wire.

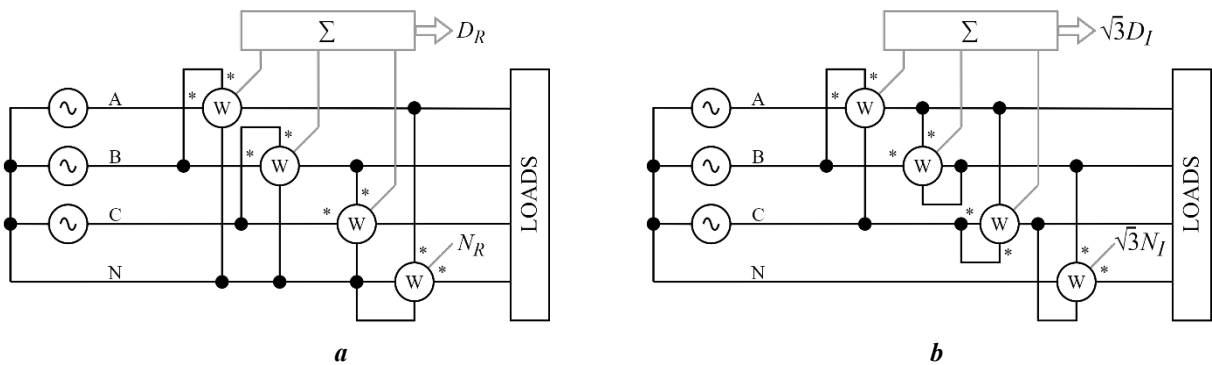

Fig. 2

According to (7), the decomposition of the first harmonic current vector in the time domain takes the form of

$$\mathbf{i}_1(t) = \begin{bmatrix} i_A \\ i_B \\ i_C \end{bmatrix} = \frac{P}{U_{JI}^2} \begin{bmatrix} u_A \\ u_B \\ u_C \end{bmatrix} + \frac{Q}{U_{JI}^2 \sqrt{3}} \begin{bmatrix} u_{BC} \\ u_{CA} \\ u_{AB} \end{bmatrix} + \frac{D_R}{U_{JI}^2} \begin{bmatrix} u_A \\ u_C \\ u_B \end{bmatrix} + \frac{D_I}{U_{JI}^2 \sqrt{3}} \begin{bmatrix} u_{BC} \\ u_{AB} \\ u_{CA} \end{bmatrix} + \frac{N_R}{U_{JI}^2} \begin{bmatrix} u_A \\ u_A \\ u_A \end{bmatrix} + \frac{N_I}{U_{JI}^2 \sqrt{3}} \begin{bmatrix} u_{BC} \\ u_{BC} \\ u_{BC} \end{bmatrix}. \quad (9)$$

The vector of compensation currents for distributed filtration can be synthesized by (9) according to the given values of scalar inactive powers.

In the presence of higher harmonic currents in the four-wire transmission line, the line current vector has the form $\mathbf{i}(t) = \mathbf{i}_1(t) + \mathbf{i}_H(t)$. Formulas for determining powers (6)-(8) do not change, and the power loss in the transmission line is

$$\begin{aligned} \Delta P &= \frac{1}{T} \int_T [i_A^2(t)r + i_B^2(t)r + i_C^2(t)r + i_N^2(t)r_N] dt = \\ &= \frac{r}{T} \int_T \mathbf{i}^{\wedge}(t)(\mathbf{E} + 3\rho \bar{\mathbf{e}}_0 \bar{\mathbf{e}}_0^{\wedge}) \mathbf{i}(t) dt = r \bar{\mathbf{i}}^{\wedge} (\mathbf{E} + 3\rho \bar{\mathbf{e}}_0 \bar{\mathbf{e}}_0^{\wedge}) \bar{\mathbf{i}}^* + \Delta P_H = \\ &= r [\bar{\mathbf{i}}^{\wedge} \bar{\mathbf{i}}^* + 3\rho (\bar{\mathbf{i}}^{\wedge} \bar{\mathbf{e}}_0) (\bar{\mathbf{i}}^{\wedge} \bar{\mathbf{e}}_0)^*] + \Delta P_H = \\ &= r \left[(P^2 + Q^2 + D_R^2 + D_I^2 + N_R^2 + N_I^2) U_{JI}^{-2} + 3\rho \times \frac{(N_R - jN_I)}{U_{JI}} \times \frac{(N_R - jN_I)^*}{U_{JI}} \right] + \Delta P_H = \\ &= [P^2 + Q^2 + D_R^2 + D_I^2 + (N_R^2 + N_I^2)(1 + 3\rho) + H^2] r U_{JI}^{-2}, \end{aligned} \quad (10)$$

where $\rho = r_N / r$ is the resistive parameter ratio of transmission line neutral and line wires; \mathbf{E} is the unit matrix of dimension 3; $H^2 = \Delta P_H U_L^2 / r$ is square of the power losses of higher harmonic currents.

The short circuit power is

$$P_0 = \frac{1}{T} \int_T [u_A^2(t) / r + u_B^2(t) / r + u_C^2(t) / r] dt = 3U_{\phi}^2 / r = U_{JI}^2 / r.$$

The square of apparent power determined by [15, 16] has the following decomposition into quadratic components:

$$S^2 = \Delta P P_0 = P^2 + Q^2 + D_R^2 + D_I^2 + (N_R^2 + N_I^2)(1 + 3\rho) + H^2. \quad (11)$$

This expression differs from known formulas from other power theories by the presence of a multiplier $(1 + 3\rho)$ that enhances the negative impact of power components N_R, N_I in a three-phase four-wire power system due to the additional power losses in the neutral wire.

For the possibility of experimental verification of the current decomposition (9) and the power losses decomposition (10), we first consider the linear load described by the complex conductivity $\bar{Y}_A, \bar{Y}_B, \bar{Y}_C$ enabled to the four-wire power system of the star. The vector of the first harmonic line currents is as follows:

$$\bar{\mathbf{i}} = \begin{bmatrix} \dot{I}_A \\ \dot{I}_B \\ \dot{I}_C \end{bmatrix} = \begin{bmatrix} \dot{U}_A \bar{Y}_A \\ \dot{U}_B \bar{Y}_B \\ \dot{U}_C \bar{Y}_C \end{bmatrix} = U_{\phi} \begin{bmatrix} \bar{Y}_A \\ \tilde{a} \bar{Y}_B \\ \tilde{a}^2 \bar{Y}_C \end{bmatrix}.$$

Complex powers by formula (4) are determined from the ratios:

$$P - jQ = \bar{\mathbf{i}} \wedge \bar{\mathbf{u}}_+^* = U_\phi \left\| \begin{array}{c} \bar{Y}_A \\ \tilde{a}\bar{Y}_B \\ \dot{a}\bar{Y}_C \end{array} \right\|^\wedge \times U_\phi \left\| \begin{array}{c} \mathbf{1} \\ \tilde{a} \\ \dot{a} \end{array} \right\|^{*\ast} = U_\phi^2 (\bar{Y}_A + \bar{Y}_B + \bar{Y}_C);$$

$$D_R - jD_I = \bar{\mathbf{i}} \wedge \bar{\mathbf{u}}_-^* = U_\phi \left\| \begin{array}{c} \bar{Y}_A \\ \tilde{a}\bar{Y}_B \\ \dot{a}\bar{Y}_C \end{array} \right\|^\wedge \times U_\phi \left\| \begin{array}{c} \mathbf{1} \\ \dot{a} \\ \tilde{a} \end{array} \right\|^{*\ast} = U_\phi^2 (\bar{Y}_A + \dot{a}\bar{Y}_B + \tilde{a}\bar{Y}_C);$$

$$N_R - jN_I = \bar{\mathbf{i}} \wedge \bar{\mathbf{u}}_0^* = U_\phi \left\| \begin{array}{c} \bar{Y}_A \\ \tilde{a}\bar{Y}_B \\ \dot{a}\bar{Y}_C \end{array} \right\|^\wedge \times U_\phi \left\| \begin{array}{c} \mathbf{1} \\ \mathbf{1} \\ \mathbf{1} \end{array} \right\|^{*\ast} = U_\phi^2 (\bar{Y}_A + \tilde{a}\bar{Y}_B + \dot{a}\bar{Y}_C).$$

In particular, for a three-phase four-wire power supply system with a phase voltage value $U_\phi = 220V$ and values of complex resistances of separate phases:

$$\bar{Z}_A = R_A = 5\Omega, \bar{Z}_B = R_B + jX_B = (4 - j)\Omega, \bar{Z}_C = R_C + jX_C = (1 + 4j)\Omega$$

we have the following numerical power values in SI units:

$$P = U_\phi^2 \operatorname{Re}(\bar{Y}_A + \bar{Y}_B + \bar{Y}_C) = 23895.78; \quad Q = -U_\phi^2 \operatorname{Im}(\bar{Y}_A + \bar{Y}_B + \bar{Y}_C) = 8534.21;$$

$$D_R = U_\phi^2 \operatorname{Re}(\bar{Y}_A + \dot{a}\bar{Y}_B + \tilde{a}\bar{Y}_C) = -9757.8; \quad D_I = -U_\phi^2 \operatorname{Im}(\bar{Y}_A + \dot{a}\bar{Y}_B + \tilde{a}\bar{Y}_C) = -11657.94;$$

$$N_R = U_\phi^2 \operatorname{Re}(\bar{Y}_A + \tilde{a}\bar{Y}_B + \dot{a}\bar{Y}_C) = 14878.33; \quad N_I = -U_\phi^2 \operatorname{Im}(\bar{Y}_A + \tilde{a}\bar{Y}_B + \dot{a}\bar{Y}_C) = 3123.74,$$

Computer simulation of integral expressions (6)-(8) gives similar numerical values.

For the same loading of renewable generator reserve powers during distributed active filtration, squares of inactive powers are divided into approximately the same groups by the number of compensators available. So with two compensators, the first group should include N_R and N_I , other inactive powers Q, D_R, D_I included in the second group. In the presence of three compensators, N_R is the first group, D_I, N_I is the second group, Q, D_R is the third. With four compensators, N_R is the first group, D_I is the second group, D_R is the third group, Q, N_I is the fourth.

The active current $\mathbf{i}_p(t)$, according to Fryze in the decomposition (9), provides the required active power of the load with minimum possible power losses in the transmission line [16, 17], which is equal to the relative value:

$$\Delta P_{MIN} / r = \frac{1}{T} \int_T \mathbf{i}_p^\wedge(t) \mathbf{i}_p(t) dt = I_p^2 = P^2 U_{JI}^{-2} = 393577.$$

Each of the inactive components of current decomposition (9) contributes to the total power losses:

$$I_Q^2 = \Delta P_Q / r = \frac{1}{T} \int_T \mathbf{i}_Q^\wedge(t) \mathbf{i}_Q(t) dt = Q^2 U_{JI}^{-2} = 502.01;$$

$$I_{DR}^2 = \Delta P_{DR} / r = \frac{1}{T} \int_T \mathbf{i}_{DR}^\wedge(t) \mathbf{i}_{DR}(t) dt = D_R^2 U_{JI}^{-2} = 656.28;$$

$$I_{DI}^2 = \Delta P_{DI} / r = \frac{1}{T} \int_T \mathbf{i}_{DI}^\wedge(t) \mathbf{i}_{DI}(t) dt = D_I^2 U_{JI}^{-2} = 936.77;$$

$$I_{NR}^2 = \Delta P_{NR} / r = \frac{1}{T} \int_T \mathbf{i}_{NR}^\wedge(t) (\mathbf{E} + 3\rho \bar{\mathbf{e}}_0 \bar{\mathbf{e}}_0^\wedge) \mathbf{i}_{NR}(t) dt = (1 + 3\rho) N_R^2 U_{JI}^{-2} = 3814.49;$$

$$I_{NI}^2 = \Delta P_{NI} / r = \frac{1}{T} \int_T \mathbf{i}_{NI}^\wedge(t) (\mathbf{E} + 3\rho \bar{\mathbf{e}}_0 \bar{\mathbf{e}}_0^\wedge) \mathbf{i}_{NI}(t) dt = (1 + 3\rho) N_I^2 U_{JI}^{-2} = 168.14.$$

Replacement of linear load of phase *A* with a circuit containing a sequential connection of the active resistance $R_A/2=2.5\Omega$ and the ideal diode causes the flow of phase current $i_A(t)=[|u_A(t)|+u_A(t)]/R_A$, which does not change the considered mode of the main harmonic of line currents, but causes the appearance of additional currents of higher harmonics in the transmission line, described by the vector of instantaneous values $\mathbf{i}_H(t)=|u_A(t)|/R_{AB}||1\ 0\ 0||^{\wedge}$. It corresponds to the relative power losses of higher harmonic currents:

$$\Delta P_H / r = I_H^2 = \frac{r+r_N}{rT} \int_T \mathbf{i}_H^{\wedge}(t)\mathbf{i}_H(t)dt = \frac{U_{\phi}^2(1+\rho)}{R_A^2} = 2901.63.$$

Relative total power losses according to (10):

$$\Delta P / r = I_P^2 + I_Q^2 + I_{DR}^2 + I_{DI}^2 + I_{NR}^2 + I_{NI}^2 + I_H^2 = I^2 = 12915.1.$$

Graphs of changes in the instantaneous values of currents and powers, as well as relative power losses corresponding to each of the quadratic components of apparent power for nonlinear load, are shown in Fig. 3. The data of the virtual experiment fully confirmed the calculated values of the relative losses from each of the seven orthogonal components of the current decomposition (10) and the independence of integral powers (6)-(8) from the currents of higher harmonics.

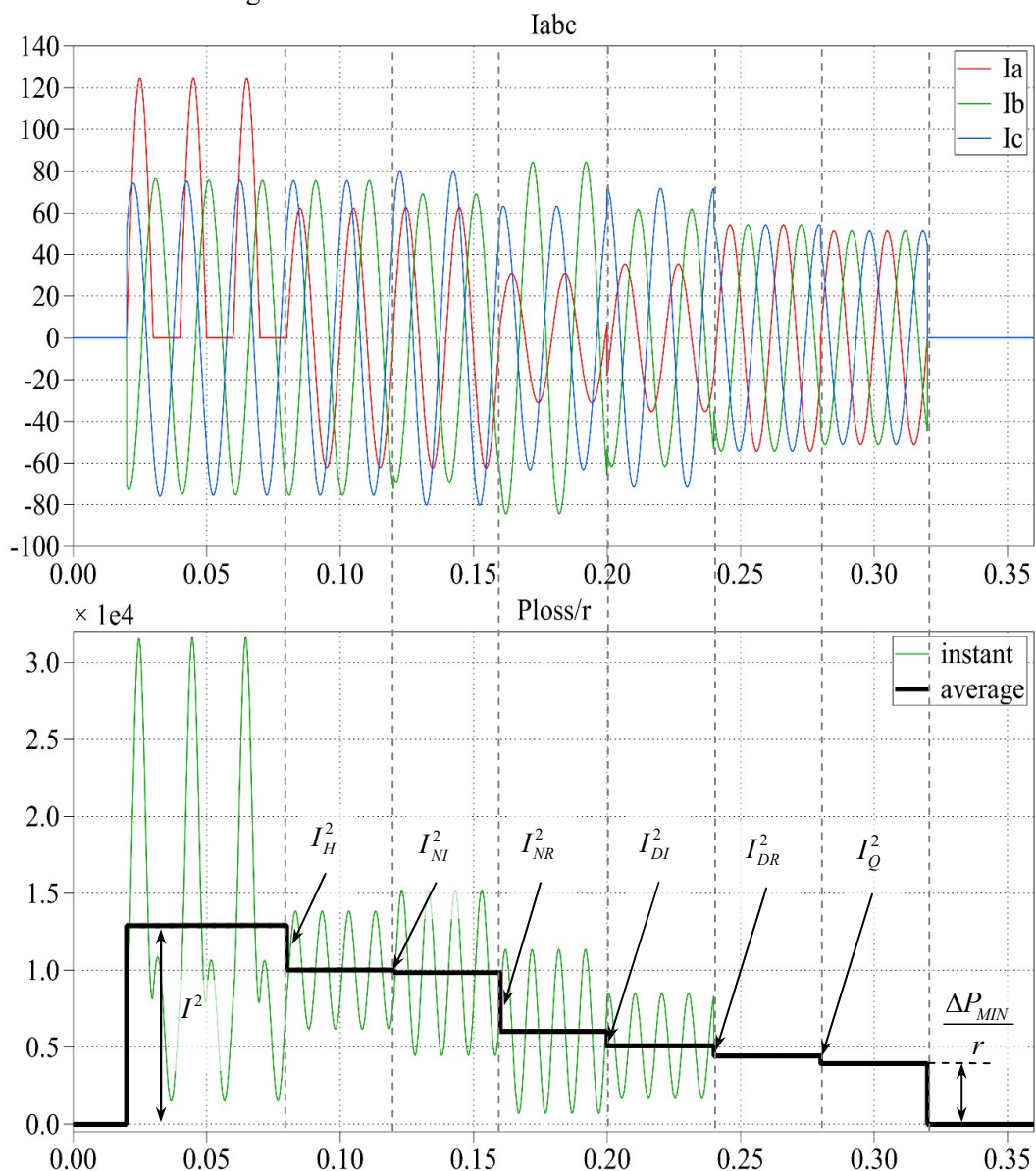

Fig. 3

Conclusions.

1. It is proposed to identify the sinusoidal mode of the three-phase four-wire power system under the condition of asymmetric source with six mutually orthogonal components of the three-coordinate vector of line currents, each of which determines a separate contribution to the power losses of the transmission line, but only the component of the active current according to Fryze transfers energy to the load, the rest are subject to compensation in the process of concentrated or distributed filtration.

2. It is shown that the unbalance power is due to four mutually orthogonal components of the three-coordinate vector of line currents with defined reference voltage vectors, each of which is proportional to a separate orthogonal component of the unbalance power. Integral formulas for determining the scalar values of the four specified orthogonal components of unbalance powers have been obtained, which open the possibility of considering their contribution to the deterioration of the power quality and synthesizing the control signals for distributed active filtration. It is shown that these formulas retain the initial values of the power in the presence of currents of higher harmonics.

3. The connection between the four specified orthogonal components of the unbalance power and the parameters of the linear unbalanced load was established, which made it possible to verify these integral formulas using a computer experiment. It is analytically established and experimentally confirmed that the squares of the two orthogonal components of the unbalance powers associated with the current of the neutral wire are included in the decomposition of the square of apparent power and power losses with the multiplier, depending on the ratio of the resistances of the transmission line of the three-phase four-wire power system.

Роботу виконано за держбюджетною темою «Розробка наукових основ та принципів побудови напівпровідникових перетворювачів з розширеними функціональними можливостями і методів керування ними в системах з джерелами розосередженої генерації» (шифр «АДАПТЕР»), державний реєстраційний номер 0120U002005 (КПКВК 6541030).

1. Hryb O.H., Sokol E.I., Zharkin A.F., Vasylychenko V.I., Tesik Yu.F. Quality of electrical energy. Volume 3. Methods and means of improving the quality of electrical power. Kharkiv: Hraf-X, 2014. 292 p. (Ukr)
2. Definitions for the measurement of electric power quantities under sinusoidal non-sinusoidal, balanced or unbalanced conditions. IEEE Std. 1459-2010, 2010. DOI: <https://doi.org/10.1109/IEEESTD.2010.5439063>
3. Syrotyn Yu.A., Hryb O.H., Hapon D.A., Ierusalymova T.S., Shvets S.V. Accounting for inactive components of apparent power. *Bulletin of NTU KhPI, Hydraulic machines and hydrounits*. 2017. No 22 (1244). Pp. 71–76. (Rus)
4. Fortescue, C.L. Method of symmetrical coordinates applied to the solution of polyphase networks. Proc. 34th Annual Convention of the AIEE, Atlantic City, NJ, USA, 1918. Vol. 37. No 3. Pp. 1027–1140. DOI: <https://doi.org/10.1109/T-AIEE.1918.4765570>
5. Vo T., Ravishankar J., Nurdin H.I., Fletcher J. A novel controller for harmonics reduction of grid-tied converters in unbalanced networks. *Electr. Power Syst. Res.* 2018. Vol. 155. Pp. 296–306. DOI: <https://doi.org/10.1016/j.epsr.2017.10.019>
6. Salmerón P., Vázquez J.R., Herrera R.S., Litrán S.P. Apparent power and power factor in unbalanced and distorted systems. Applications in three phase load compensations. *RE&PQJ*, Vol. 1. No 5. 2007. DOI: <https://doi.org/10.24084/repqj05.312>
7. Pedro A. Blasco, Rafael Montoya-Mira, José M. Diez, Rafael Montoya. An Alternate Representation of the Vector of Apparent Power and Unbalanced Power in Three-Phase Electrical Systems. *Appl. Sci.* 2020. No 10. 3756. DOI: <https://doi:10.3390/app10113756>
8. Vijay A.S., Doolla Suryanarayana, Chandorkar Mukul C. Unbalance mitigation strategies in microgrids. *IET Power Electron.* 2020. Vol. 13. Iss. 9. Pp. 1687-1710. DOI: <https://doi.org/10.1049/iet-pel.2019.1080>
9. Artemenko M.Y., Batrak L.M., Mykhalskyi V.M., Polishchuk S.Y. Energy performance optimization of the three phase four wire power supply system with a shunt active filter in the unbalanced sinusoidal mode. *Tekhnichna elektrodynamika*. 2015. No 2. Pp. 30-37. (Ukr)
10. Mykhalskyi V.M., Sobolev V.M., Chopyk V.V., Shapoval I.A. The minimization strategy of undesirable instantaneous power components with different topologies of shunt active filter. *Tekhnichna elektrodynamika*. 2014. No 1. Pp. 41-50. (Ukr)
11. Czarnecki L.S., Haley P.M. Unbalanced Power in Four-Wire Systems and its Reactive Compensation. *IEEE Transactions on Power Delivery. IEEE Transactions on Power Delivery*. 2015. Vol. 30. No 1. Pp. 53-63. DOI: <https://doi.org/10.1109/TPWRD.2014.2314599>
12. Augusto Matheus dos Santos Alonso, Danilo Iglesias Brandao, Elisabetta Tedeschi, Fernando Pinhabel Marafão. Distributed selective harmonic mitigation and decoupled unbalance compensation by coordinated inverters in

three-phase four-wire low-voltage networks. *Electric Power Systems Research*. Sept. 2020. Vol. 186. Pp. 1–14. DOI: <https://doi.org/10.1016/j.epsr.2020.106407>

13. Guodong Liu, Thomas B. Ollis, Bailu Xiao, Xiaohu Zhang, Kevin Tomsovic. Distributed energy management for community microgrids considering phase balancing and peak shaving. *IET Gener. Transm. Distrib.* 2019. Vol. 13. Iss. 9. Pp. 1612-1620. DOI: <https://doi.org/10.1049/iet-gtd.2018.5881>

14. Boiko V.S., Boiko V.V., Vydolob Yu.F. Theoretical Fundamentals of Electrical Engineering: Tutorial. Steady-state modes of linear electric circles with lumped parameters. Vol. 1. Kyiv: Polytechnic Publishing House. 2004. 272 p. (Rus)

15. Artemenko M.Yu., Mykhalskyi V.M., Polishchuk S.Y. Definition of apparent power of three-phase power supply systems as a theoretical basis for development of energy-efficient shunt active filters. *Tekhnichna elektrodynamika*. 2017. No 2. Pp. 25-34. (Ukr) DOI: <https://doi.org/10.15407/techned2017.02.025>

16. Artemenko M., Batrak L., Polishchuk S. New definition formulas for apparent power and active current of three-phase power system. *Przeglad Elektrotechniczny*. 2019. No 95(8). Pp. 81–85. DOI: <https://doi.org/10.15199/48.2019.08.20>

17. Polishchuk S.Y., Artemenko M.Yu., Mykhalskyi V.M., Batrak L.M., Shapoval I.A. Shunt active filter control strategy with partial decrease of zero-sequence voltage in three-phase four-wire system. *Tekhnichna elektrodynamika*. 2013. No 3. Pp. 12-19. (Ukr)

УДК 621.314

ІДЕНТИФІКАЦІЯ ПОТУЖНОСТІ НЕБАЛАНСУ ТРИФАЗНОЇ ЧОТИРИПРОВІДНОЇ СИСТЕМИ ЖИВЛЕННЯ ДЛЯ ПОТРЕБ ЇЇ РОЗПОДІЛЕНОЇ КОМПЕНСАЦІЇ

М.Ю. Артеменко¹, докт.техн.наук, В.В. Чопик², канд.техн.наук, В.М. Михальський², чл.-кор. НАН України, І.А. Шаповал², докт.техн.наук, С.Й. Поліщук², канд.техн.наук

¹ НТУ України «Київський політехнічний інститут ім. І. Сікорського», пр. Перемоги, 37, Київ, 03056, Україна.

² Інститут електродинаміки НАН України, пр. Перемоги, 56, Київ, 03057, Україна.

E-mail: mikhalsky@ied.org.ua

Ідея розподіленої активної фільтрації полягає в компенсації струмів вищих гармонік та небажаних складових потужності основної мережі інверторами перетворювачів відновлюваної енергії приєднаної мікромережі, що мають резерви повної потужності. Задля зручності розподіленої компенсації запропоновано ідентифікувати синусоїдний режим трифазної чотирипровідної системи живлення за умови симетричного джерела шістьма взаємно ортогональними складовими трикоординатного вектора лінійних струмів. Показано, що потужність небалансу зумовлена чотирма взаємно ортогональними складовими трикоординатного вектора лінійних струмів з визначеними опорними векторами напруг, кожен з яких пропорційний окремій ортогональній складовій потужності небалансу. Отримано інтегральні формули для визначення скалярних значень чотирьох зазначених ортогональних складових потужностей небалансу, що відкривають можливість обліку їхнього внеску у погіршення якості електричної енергії та синтезу керуючих сигналів для активної розподіленої фільтрації. Встановлено зв'язок між чотирма зазначеними ортогональними складовими потужності небалансу та параметрами лінійного незбалансованого навантаження, що дало змогу верифікувати ці інтегральні формули за допомогою комп'ютерного експерименту. Аналітично встановлено та експериментально підтверджено, що квадрати двох ортогональних складових потужностей небалансу, пов'язані зі струмом нейтрального проводу, входять в декомпозиції квадрату повної потужності та потужності втрат із множником, що залежить від співвідношення опорів лінії передачі трифазної чотирипровідної системи живлення. Бібл. 17, рис. 3.

Ключові слова: потужність небалансу, мікромережа, стратегія керування паралельним активним фільтром, розподілена фільтрація

Надійшла 11.03.2022