

INFORMATION TECHNOLOGY FOR PROTECTING DIESEL-ELECTRIC STATION
RELIABLE OPERATION

O.F. Yenikieiev^{1*}, L.N. Shcherbak^{2**}

¹ Donbass State Engineering Academy,
str. Akademicheskaiia, 72, Kramatorsk, 84313, Ukraine,

e-mail: al_enikeev@bigmir.net

² Kyiv international university,
str. Lvivska, 49, Kyiv, 03179, Ukraine,

e-mail: prof_scherbak@ukr.net

The idea of obtaining a quantitative estimation of the identity of the working cycle of a diesel-electric station is proposed on the basis of processing of the frequency-modulated signal of the speed of the crankshaft. The method of measuring fluctuations is developed and on the basis of it the information-measuring device is constructed. As a result of the analysis of the deterministic mathematical model of the kinematic scheme of a diesel-electric station in the form of a mechanical system with ten degrees of will, transfer functions are obtained that establish information communications between the torque moments of the cylinders and the signal of fluctuations. The information technology for assessing the identity of the diesel cycle work cycles is based on the frequency representation of the signal of fluctuations, transfer functions and torques of cylinders. It consists in solving a redefined system of algebraic equations using a non-solving minimization algorithm. References 18, tables 2, figures 4.

Keywords: hardware, computer system, information technology, metrological characteristics, measurement method, frequency-modulated signal.

Introduction. Diesel power stations (DES) have been widely used in rail and sea transport as autonomous power sources. Their technical and economic and environmental indicators determine the regular configuration of the work cycles of the power unit [16]. The accuracy of setting the angles of fuel and air supply to the cylinders of the diesel engine with the corresponding distribution shafts creates the conditions for ensuring the identity of its working cycles [17, 18]. The connections of the crankshaft with distributive ones provide a communication drive on the basis of gear wheels, the precision of which is standardized in the form of tolerances on the cinematic error [13]. Errors in the production of camshafts, several gears of the coupling drive form an interval of uncertainty around the optimum angles of fuel and air supply to the cylinder, which changes the regular setting of the power unit. Using hardware that programmatically sets individual fuel and air supply angles for each cylinder allows you to reduce the adjustment error and, accordingly, improve the identity of the work cycles. The construction of these hardware is based on the use of a well-known method for measuring the indicative diagrams of each cylinder and further comparison to assess their identity. The use of manual labor, a sufficiently large number of cylinders and the absence of output signals in the primary pressure transducers significantly limit the performance of the known method of evaluation. Therefore, the authors propose the idea of obtaining a quantitative assessment of the identity of the working cycles of the DPS on the basis of digital processing of the frequency-modulated signal of the speed of the crankshaft. According to the results of the evaluation, the corresponding hardware of the computer system (KS) form the programmatic changes in the settings for the processes of fuel and air supply to the cylinders in order to ensure the identity of the operating cycles of the DPS. Solving this task will ensure fuel economy at 5% [4] and reduce the probability of overloading of individual cylinders. It will also increase the life of the unit and reduce the cost of prevention, maintenance and repair. Thus, the choice of the method for obtaining input information, the construction of hardware with corresponding metrological characteristics and performance, the development of algorithmic support is an actual scientific and applied problem.

Analysis of literary data and problem statement. The issue of ensuring reliable operation of the DPS on the basis of measurements of the fluctuations in the speed of the crankshaft is given sufficient attention in the technical literature. In the papers [9–12] a mathematical model of fluctuations was developed in the form of a linear periodically correlated random process. It is proved that the model describes the dynamics of cylinder capacities and is suitable for diagnosing of the DES due to uneven rotation of the

crankshaft. The paper [14] presents the results of investigations of the non-normality of the crankshaft rotation of the DNP 6NVD48UA. The measuring fluctuation converter and the method of calculating the average effective pressure, engine power, excess air coefficient and exhaust gas temperature have been developed. In the paper [5], a method is proposed to improve the accuracy of control of the process of fuel supply to cylinders based on measurements of the amplitude of the oscillations of the angular velocity of rotation and displacement by the phase of their extremums relative to the upper dead center of the corresponding cylinder. In the paper [15] a mathematical model of the crankshaft rolling wheels in the form of a mechanical system with one degree of freedom is investigated. In order to reduce the effect of noise on the information signal in [2], it is proposed to use a high-pass filter with a finite impulse response. The technique of processing the signal of uneven rotation of the crankshaft using the possibilities of the Matlab software environment is developed. The disadvantage of known measuring transducers of the fluctuations in the speed of the crankshaft is the lack of an analysis of their metrological characteristics.

Relevance. Unsatisfactory metrological characteristics and productivity of known hardware for fluctuation measurements of the frequency-modulated signal, the lack of algorithmic and application software for processing of incoming information.

Objective. Improving the accuracy and productivity of the process of evaluating the identity of the DPS operating cycles on the basis of fluctuation measurements of the frequency-modulated signal of the instantaneous rotation speed of the crankshaft.

Research objectives. 1. Development of the method for measuring the fluctuations of the frequency-modulated signal and the construction on the basis of its hardware of the corresponding metrological characteristics.

2. Analysis of the deterministic mathematical model of the kinematic scheme of a multicylinder diesel engine.

3. Based on the frequency representation of the signal of fluctuations in the development of information technology for assessing the identity of the working cycles of the DPS.

Solving problems. The depth of modulation of the frequency-modulated signal of the rotation speed of the crankshaft does not exceed 0.05 [6]. Therefore, the procedure of measurements of the fluctuation signal is rather complicated and requires the development of hardware having a small uncertainty interval around the nominal conversion characteristic. Construction of the information measuring device (IMD) begins with the analysis of the components of the error of the primary converter (PS):

- the error recovery of the analog signal from discrete samples that is determined for its frequency representation by means of expression

$$\delta_1 = \frac{t_0}{8} \sqrt{0.1 \sum_{i=1}^{10} \Omega_i^4} 100\%, \quad (1)$$

where t_0 is the sampling interval, Ω_i is the i -harmonic of the frequency representation of the input signal;

- the kinematic error of PC, which is determined by the authors on the example of the study of tolerances for the manufacturing of gears of different accuracy class and is given in Table 1. The following expression is used to calculate the kinematic error

$$\delta_2 = \frac{\Delta m}{m} 100\%, \quad (2)$$

where Δm is the tolerance for the kinematic error of the gear, m is the module;

- the PC dynamic error lies in time shifts of discrete samples of the temporal realization of the fluctuation signal, which arise as a result of the presence of the kinematic one.

Table 1

Accuracy class of gears	4	5	6	7	8
$\delta_2, \%$	0.80	1.25	2.00	2.75	4.00
Error of deviation measurements, %	16.0	25.0	40.0	55.0	80.0

Data of the table permit to make a conclusion: to build the IMD with the corresponding metrological

characteristics, it is necessary to develop a method that reduces the influence of the kinematic error on the result of measurements of the fluctuations of the frequency-modulated signal. PC certification is possible by solving this problem. As a result of its implementation, we obtain corrections that take into account the CS in determining the fluctuation signal. The IMD also includes synchronization hardware with the phase of rotation of the PC shaft.

To compensate the kinematic error, the authors propose a method of multimeasurements of time intervals that are formed by the selected feature of the primary converter and correspond to the full rotation of its shaft. Using the method of instantaneous velocity measurements, the kinematic error does not affect the length of the time intervals that form the IMD as information signals. However, here arises the dynamic error in the time shifts of discrete readings of the signals of the measurement information, which are a consequence of the kinematic error. It is necessary to estimate the dynamic error of the primary converter of the instantaneous rotation speed. Its absolute value is found as follows

$$\Delta_{11} = \frac{1}{T} \int_0^T [\Delta\omega(\Omega t + \Omega\sigma_1) - \Delta\omega(\Omega t)] dt, \quad (3)$$

where σ_1 is the standard deviation of the time shift of discrete samples, which is established on the basis of tolerances for the manufacture of the PC [8].

For a harmonious representation of the fluctuation signal, the last expression after mathematical transformations takes the following form

$$\Delta_{11,i} = \frac{2A_i}{\pi} \sin(\varphi_i - 0.5i\Omega\sigma_1) \sin(i\Omega\sigma_1). \quad (4)$$

The relative error of the harmonious representation of the fluctuation signal is obtained in the expression

$$\delta_i = \frac{2}{\pi} \sin(\varphi_i - 0.5i\Omega\sigma_1) \sin(i\Omega\sigma_1). \quad (5)$$

The dynamic error of the PC is determined taking into account the contribution of the harmonic components to the fluctuation signal in the following way

$$\delta_3 = \sqrt{\frac{\sum_{i=1}^{10} (A_i \delta_i)^2}{\sum_{i=1}^{10} A_i^2}}. \quad (6)$$

The results of calculations of the dynamic error of the PC are given in Table 2. The efficiency of the method of measurements of the fluctuation signal of the rotation speed, proposed by the authors, is established by comparing the data of Tables 1 and 2.

Table 2

Accuracy class of the primary converter	4	5	6	7	8
Error of deviation measurement, %	3.10	4.80	7.40	9.90	14.10

Using the method of hardware compensation of the kinematic error for the IMD construction, the output signal of the PC with a help of the counter and the decoder is converted into several impulse sequences. The position of the pulses in them corresponds to the moments of passage at the sensitive element of the PC chosen mark. Then the signal is fed to the input of the corresponding channel for measuring of time intervals. The number of these channels as a part of the IMD is determined by the number of the PC marks. The hardware implementation of channels for measurements was made on the basis of the time discretization method. The elimination of the mutual overlapping of the

output signal channels when they are combined by the ABO scheme into the measurement information signal for the CS is performed using counters. The volume of the latter and the frequency of the reference generator are selected so that the counter overflow can be performed in a time slightly less than the average period of the pulse sequence. So the calibrated time interval is excluded from the measurement information of each channel.

The device for measuring of the fluctuation signal was designed (Fig.1), described in the

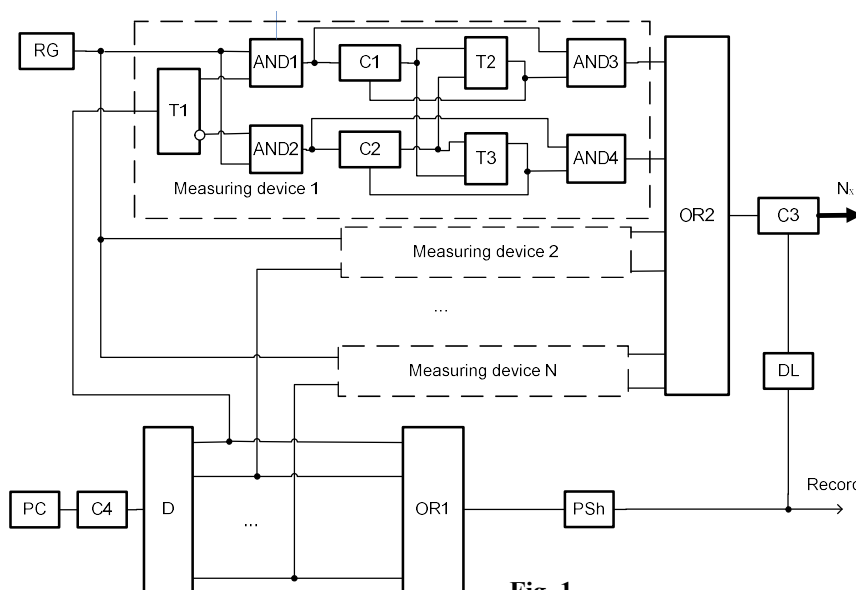

Fig. 1

work [1]. The figure shows: RG is the reference generator; D is the decoder; C1,..., C4 are the pulse counters; ABO1, ABO2 are the logic schemes ABO; TA1,..., TA4 are the logic schemes TA; N is the number of channels for measurements; F is the pulse former; N_x is the output code; PSh is the pulse shaping; T1,..., T3 are the triggers; Dl is the delay line. The measuring device has a two-channel structure. It measures the duration of the pulses that form the direct and inverse outputs of the T1 blocks. The measurement information signal for the CS is formed by the ABO2 scheme. The counter C3 converts this signal into a binary code and provides data of the CS parallel interface. Block F forms the write signal of the binary code in the CS operative memory and by means of the Dl block switches the counter C3 to the zero state.

The statistical processing of the experimental data for the purpose of establishing of the IMD metrological characteristics has been performed. The sample size was 151 measurements of the IMD output signal. The basic statistical parameters of a series of measurements with repeated observations are as follows

$$\bar{X} = 2.0 \cdot 10^{-4}; \quad \sigma = 0.014248; \quad A = 0.0536; \quad E = -0.449.$$

The equation of the smoothed curve of spreading of the IMD source code has such form

$$f(x) = \frac{1}{2\sigma} e^{-\frac{|x|}{\sigma}} \quad \text{when} \quad x \in (-0.04, 0.04). \quad (7)$$

It is necessary to use the information approach to determine the error of the measurements. The chosen law of the error distribution is defined as follows

$$\ln f(x) = -\ln 2\sigma - |x|/\sigma. \quad (8)$$

Thence it follows the entropy of the IMD error

$$H\left(\frac{x}{x_n}\right) = \ln\left(2\sigma e^{\frac{\mu_1}{\sigma}}\right). \quad (9)$$

The entropy interval of the uncertainty of the IMD source code is

$$\Delta = \sigma e^{\frac{\mu_1}{\sigma}} = 0.01465. \quad (10)$$

Information technology of the processing of the instantaneous speed signal consists of such computational procedures: to calculate the average speed; to determine the array of fluctuations within the entire volume of the research data; to perform the averaging procedure for all processes of realizations and form the array of fluctuations within one revolution of the crankshaft; to supply this array in the form of a limited Fourier series. Further procedures of the processing of the CS input information in order to evaluate the identity of the operating cycles are established on the basis of an analysis of the DPS mathematical model.

When compiling the DPS deterministic mathematical model can be used the following assumptions:

- the twisting scheme of the DPS shafting is fed in the form of a mechanical system that has ten degrees of freedom (by the numbers of cylinders);
- friction is not taken into account.

The motion of the masses of the mechanical system that has ten degrees of freedom is described by the following system of differential equations [7]

$$J_i \varphi_i''(t) - e_{i+1,i}^{-1} [\varphi_{i+1}(t) - \varphi_i(t)] + e_{i,i-1}^{-1} [\varphi_i(t) - \varphi_{i-1}(t)] = M_i(t), \quad (11)$$

where $i = 1, 2, 3, \dots, 10$; J_i is the moment of inertia mass; $M_i(t)$ is the twisting moment acting in crank, without taking into account the mean value; $\varphi_i(t)$ is the twist angle of mass; $e_{i+1,i}$ is the compliance between masses. Gears are not part of the mathematical model, therefore the system of differential equations (11) is linear.

The fluctuation signal of the rotation speed of the DPS crankshaft connects with the angle of its twist the following expression

$$\Delta\omega(t) = d\varphi(t)/dt. \quad (12)$$

Taking this into account, the system of differential equations (11) acquires the following form

$$J_i \Delta\omega_i'(t) - \frac{1}{e} \int [\Delta\omega_{i+1}(t) - \Delta\omega_i(t)] dt + \frac{1}{e} \int [\Delta\omega_i(t) - \Delta\omega_{i-1}(t)] dt = M_i(t). \quad (13)$$

The Laplace transform with zero initial conditions provides the following form of the system of integro-differential equations (13)

$$\Delta\omega_i(p) - (Jep^2 + 2)^{-1} \Delta\omega_{i+1}(p) - (Jep^2 + 2)^{-1} \Delta\omega_{i-1}(p) = ep(Jep^2 + 2)^{-1} M_i(p). \quad (14)$$

After mathematical transformations, the system of equations (14) can be reduce to the following form

$$\Delta\omega_1(p) = \sum_{i=1}^{10} \frac{\Delta_i}{\Delta} M_i(p), \quad (15)$$

where $\Delta\omega_1(p)$ is the Laplace transform of the fluctuation signal of the rotation speed of the first diesel mass.

Expressions for determiners by the authors are set using the Mathcad software environment. An example of the script for setting the key determinant expression is shown in Fig. 2. Expressions of other determinants are similarly established and given in the work [3]. When setting determinants, the following expressions are used to represent the coefficients

$$a = ep(Jep^2 + 1)^{-1}, \quad b = ep(Jep^2 + 2)^{-1}, \quad c = (Jep^2 + 1)^{-1}, \quad d = (Jep^2 + 2)^{-1}.$$

$$\begin{pmatrix} 1 & -d & 0 & 0 & 0 & 0 & 0 & 0 & 0 & 0 \\ -d & 1 & -d & 0 & 0 & 0 & 0 & 0 & 0 & 0 \\ 0 & -d & 1 & -d & 0 & 0 & 0 & 0 & 0 & 0 \\ 0 & 0 & -d & 1 & -d & 0 & 0 & 0 & 0 & 0 \\ 0 & 0 & 0 & -d & 1 & -d & 0 & 0 & 0 & 0 \\ 0 & 0 & 0 & 0 & -d & 1 & -d & 0 & 0 & 0 \\ 0 & 0 & 0 & 0 & 0 & -d & 1 & -d & 0 & 0 \\ 0 & 0 & 0 & 0 & 0 & 0 & -d & 1 & -d & 0 \\ 0 & 0 & 0 & 0 & 0 & 0 & 0 & -d & 1 & -d \\ 0 & 0 & 0 & 0 & 0 & 0 & 0 & 0 & -c & 1 \end{pmatrix} \rightarrow 5 \cdot d^8 - c \cdot d^9 + 10 \cdot c \cdot d^7 - 20 \cdot d^6 - 15 \cdot c \cdot d^5 + 21 \cdot d^4 + 7 \cdot c \cdot d^3 - 8 \cdot d^2 - c \cdot d + 1$$

Fig. 2

Calculation of the logarithmic amplitude-frequency characteristics (LAFCH) is performed in MATLAB. The results of the calculations are shown in Fig. 3. The search for zeros and poles of the transfer functions allows them to be represented as a serial connection of the elementary circuits. With this representation of the transfer function, the mathematical model can be simplified by canceling the roots of the numerator and denominator, as well as the rejection of unstable and second-order roots.

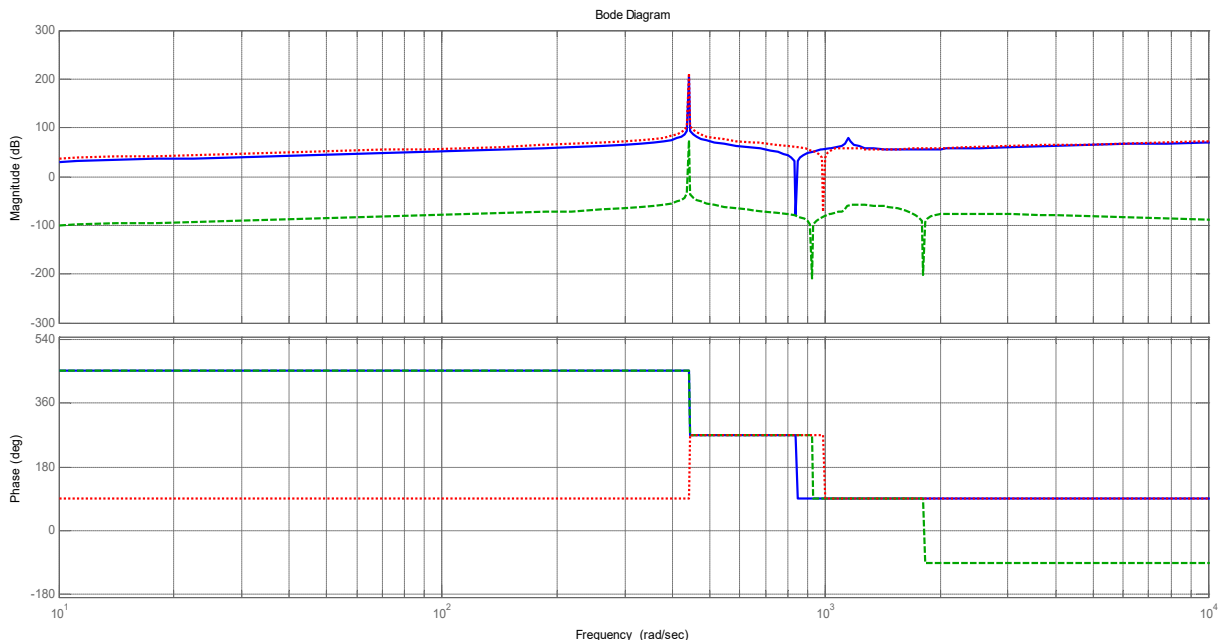

Fig. 3

The twisting moment, that forms its cylinder on the crankshaft of the diesel engine, is fed as a limited Fourier series. With such representation, it is possible to organize the changes in the fuel and air supply to the cylinder configuration in the form of an amplitude coefficient. If the value is not one, you need to change the fuel and air supply settings to the corresponding diesel cylinder. The phase delay of the processes of the fuel and air supply to the diesel cylinders in reference to the first is a multiple of 360 can be

calculated taking into account the following sequence of their operation: 1-6-10-2-4-9-5-3-7-8. Mathematically, the twisting moment is described by the following equation

$$M_i(t) = D_i \sum_{k=1}^n A_k \sin(k\Omega t + \psi_k). \quad (16)$$

Computer simulation indicates the graphs of fluctuations of the instantaneous rotation speed of the first mass within one turn of the DPS crankshaft with various settings of the fuel equipment of the power unit (Fig. 4, 1 is the *standard settings*, 2 is the *fuel is not supplied to the first cylinder*, 3 is the *fuel is not supplied to the second cylinder*). The fuel supply to the first cylinder is cut off when $D_1 = 0$, to the second cylinder – when $D_2 = 0$.

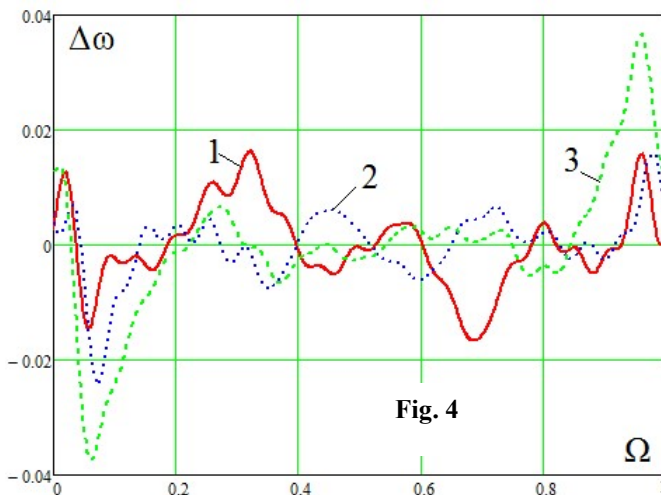

The CS hardware evaluates the identity of the DPS operating cycles in the magnitude of the coefficients, for the determination of which, the system of equations of this type is solved

$$BD = \Delta\omega_1, \quad (17)$$

where B is the matrix, the coefficients of which are determined on the basis of the LAFCH transfer functions of the cylinder-crankshaft tracks, depending on the chosen calculation method; D is the vector-column of the amplitude coefficients; $\Delta\omega_1$ is the vector-column of the time realization of the fluctuation signal of the first mass. In its frequency representation, the coefficients of the matrix are defined as follows

$$B_{i,j} = \sum_{i=1}^{10} W_i(j\Omega) M_i(j\Omega). \quad (18)$$

If the frequency representation of the fluctuation signal of the first mass exceeds 10 harmonic components, in that case the system of equations (18) is over determined. Therefore, it is possible to apply the algorithm of discrepancy minimization for calculating of the optimal values of the coefficients D_i . The corresponding hardware of the CS forms the program changes in the settings of the fuel supply to the diesel cylinders based on the calculation results.

Conclusions

1. It is proposed a method of fluctuation measurements of a frequency-modulated signal, which due to the use of hardware compensation of the kinematic error of the manufacture of primary converters provides the required accuracy. It is built an information-measuring device with corresponding metrological characteristics and productivity.

2. A mechanical system with ten degrees of freedom is proposed as a deterministic mathematical model of the diesel power stations. The mass motions of the mathematical model are described by the system of integro-differential equations. It is obtained a system of algebraic equations based on the use of the Laplace transform under zero initial conditions.

3. Transfer functions, which establish an information link between the twisting moment of the power unit cylinders and the fluctuation signal of the rotation speed of the first mass, are obtained as determinant relations of the system of algebraic equations. It is obtained a fluctuation signal within one rotation of the crankshaft of the diesel power stations by the computer simulation.

4. It is developed an information technology for estimating the identity of the operating cycles of the diesel power station on the basis of the frequency representation of the fluctuation signal. By solving of an over determined system of algebraic equations can be set the amplitude coefficients of the cylinders, using the size of which the computer system performs programs changes of the setting of the fuel and air supply processes.

1. Marchenko B.G., Borisenko A.N., Enikeev A.F. Device for monitoring the uneven rotation of the internal combustion engine shaft. A. with. 1538679 USSR. MKI G 01 M 15/00. No. 4428977; 1989. (Rus)

2. Bodnar B.E., Okkashov O.B., Chernyayev D.V. Determination of the method of filtration of the signal of uneven frequency of the rotation of the crankshaft of the diesel engine. *Visnyk Dnipropetrovskoho Natsionalnoho Universytetu zaliznychnoho transportu*. 2013. Issue 1 (43). Pp. 113–118. (Ukr)
3. Borisenko Ye.M., Yenikieiev O.F. Information technology for estimating the identity of the working cycles of internal combustion engines. *Informatsiini tekhnologii ta kompiuterna inzheneriia*. 2016. No 2. Pp. 21-28. (Ukr)
4. Grachev V.V. Experimental estimation of diagnostic method of diesel engines due to uneven rotation of the crankshaft. Progressive processes of technological operation of automobiles. Moskva: Moscow Automobile and Road Institute, 1982. Pp. 46-50. (Rus)
5. Grebennikov S.A., Grebennikov A.S., Nikitin A.V. Adaptive control of fuel supply by ICE according to indices of uneven rotation of the crankshaft. *Vestnik saratovskogo gosudarstvennogo tekhnicheskogo universiteta*. 2013. No 2(71). Pp. 80-83. (Rus)
6. Gorchach A.A., Mints M.Ya., Chinkov V.N. Digital signal processing in measuring technology. Kyiv: Tekhnika, 1989. 151 p. (Rus)
7. Enikeev A.F., Borisenko A.N., Samsonov V.P., Kiselev G.M. Diagnosis of diesel generator by shaft speed deviation. *Izmeritelnaia tekhnika*. 1988. No 9. Pp. 22-26. (Rus)
8. Yenikieiev O.F., Monchenko O.V., Shcherbak T.L. Metrological characteristics of the converter of instantaneous speed of rotation of a grinding wheel at diamond grinding. *Modeliuvannia ta informatsiini tekhnologii*. 2012. Issue 63. Pp. 42-48. (Ukr)
9. Marchenko B.G., Myslovich M.V. The theory of diagnostics of energy aggregates by deviation of rotating units and its practical application for diesel-electric generators: Part 1. *Tekhnichna Elektrodynamika*. 1998. No 5. Pp. 36-40
10. Part 2. *Tekhnichna Elektrodynamika*. 1998. No 6. Pp. 39-42
11. Part 3. *Tekhnichna Elektrodynamika*. 1999. No 1. Pp. 59-63
12. Part 4. *Tekhnichna Elektrodynamika*. 1999. No 4. Pp. 40-45. (Rus)
13. Myagkov V.D. Tolerances and landings. Part 2. Leningrad: Mashinostroenie, 1978. Pp. 545-1032. (Rus)
14. Pokusayev M.N., Sibiryakov K.O., Shevchenko A.V. Experimental determination of the degree of irregularity of the collapse of the shaft of the machine-propulsion complex of the ship 1557. *Vestnik AGTU*. 2008. No 2(43). Pp. 140-144. (Rus)
15. Polyakova T.A. Solution of differential equations of free and forced torsion co-oscillations of a single-mass shaft. *Vestnik SibADI*. 2012. Issue 4(26). Pp. 90-94. (Rus)
16. Challen B., Baranescu R. Diesel Engine Reference Book. Butterworth-Heinemann, 1999. 682 p.
17. Gawande S.H., Navale L.G., Nandgaonkar M.R., Butala D.S., Kunamalla S. Cylinder Imbalance Detection of Six Cylinder DI Diesel Engine Using Pressure Variation. *International Journal of Engineering Science and Technology*. 2010. Vol. 2(3). Pp. 433-441.
18. Gawande S.H., Navale L.G., Nandgaonkar M.R., Butala D.S. Harmonic Frequency Analysis of Multi-Cylinder Inline Diesel Engine Genset for Detecting Imbalance. *International Review of Mechanical Engineering*. 2009. Vol. 3. No 6. Pp. 782-787.

УДК 681.335.13

ІНФОРМАЦІЙНА ТЕХНОЛОГІЯ ЗАБЕЗПЕЧЕННЯ НАДІЙНОЇ ЕКСПЛУАТАЦІЇ ДИЗЕЛЬ-ЕЛЕКТРИЧНОЇ СТАНЦІЇ

О.Ф. Єнікєєв¹, докт.техн.наук, **Л.М. Щербак²**, докт.техн.наук

¹Донбаська державна машинобудівна академія,
вул. Академічна, 72, Краматорськ, 84313, Україна,

e-mail: al_enikeev@bigmir.net

²Київський міжнародний університет,
вул. Львівська, 49, Київ, 03179, Україна,

e-mail: prof_scherbak@ukr.net

Запропоновано ідею отримання кількісної оцінки ідентичності робочих циклів дизель-електричної станції на основі оброблення частотно-модульованого сигналу швидкості обертання колінчастого валу. Розроблено метод вимірювань флуктуацій та на його основі побудовано інформаційно-вимірювальний пристрій. У результаті аналізу детермінованої математичної моделі кінематичної схеми дизель-електричної станції у вигляді механічної системи із десятима ступенями вільності отримано передатні функції, які встановлюють інформаційні зв'язки між крутними моментами циліндрів та сигналом флуктуацій. Інформаційну технологію оцінювання ідентичності робочих циклів дизель-електричної станції розроблено на основі частотного подання сигналу флуктуацій, передатних функцій та крутних моментів циліндрів. Вона полягає у розв'язанні перевизначеної системи алгебраїчних рівнянь із використанням алгоритму мінімізації нев'язки. Бібл. 18, табл. 2, рис. 4.

Ключові слова: апаратні засоби, комп'ютерна система, інформаційна технологія, метрологічні характеристики, метод вимірювань, частотно-модульований сигнал.

ИНФОРМАЦИОННАЯ ТЕХНОЛОГИЯ ОБЕСПЕЧЕНИЯ НАДЕЖНОЙ ЭКСПЛУАТАЦИИ ДИЗЕЛЬ-ЭЛЕКТРИЧЕСКОЙ СТАНЦИИ

А.Ф. Еникеев¹, докт.техн.наук, **Л.Н. Щербак**², докт.техн.наук

¹Донбасская государственная машиностроительная академия,

ул. Академическая, 72, Краматорск, 84313, Украина,

e-mail: al_enikeev@bigmir.net

²Киевский международный университет,

ул. Львовская, 49, Киев, 03179, Украина,

e-mail: prof_scherbak@ukr.net

Предложена идея получения количественной оценки идентичности рабочих циклов дизель-электрической станции на основе обработки частотно-модулированного сигнала скорости вращения коленчатого вала. Разработан метод измерений флуктуаций и на его основе построено информационно-измерительное устройство. В результате анализа детерминированной математической модели кинематической схемы дизель-электрической станции в виде механической системы с десятью степенями свободы получены передаточные функции, которые устанавливают информационные связи между крутящими моментами цилиндров и сигналом флуктуаций. Информационная технология оценивания идентичности рабочих циклов дизель-электрической станции разработана на основе частотного представления сигнала флуктуаций, передаточных функций и крутящих моментов цилиндров. Она состоит в решении переопределенной системы алгебраических уравнений с использованием алгоритма минимизации невязки. Библ. 18, табл. 2, рис. 4.

Ключевые слова: аппаратные средства, компьютерная система, информационная технология, метрологические характеристики, метод измерений, частотно-модулированный сигнал.

1. Марченко Б.Г., Борисенко А.Н., Еникеев А.Ф. Устройство для контроля неравномерности вращения вала двигателя внутреннего сгорания. А.с. 1538679 СССР. № 4428977. 1989.
2. Боднар Б.Є., Очкасов О.Б., Черняев Д.В. Визначення методу фільтрації сигналу нерівномірності частоти обертання колінчастого валу дизеля. *Вісник Дніпропетровського національного університету залізничного транспорту*. 2013. Вип. 1(43). С. 113–118.
3. Борисенко Є.М., Єникеев О.Ф. Інформаційна технологія оцінювання ідентичності робочих циклів двигунів внутрішнього згоряння. *Інформаційні технології та комп'ютерна інженерія*. 2016. № 2. С. 21–28.
4. Грачев В.В. Экспериментальная оценка метода диагностирования дизельных двигателей по неравномерности вращения коленчатого вала. Прогрессивные процессы технологической эксплуатации автомобилей. М.: Московский автомобильно-дорожный ин-т, 1982. С. 46–50.
5. Гребенников С.А., Гребенников А.С., Никитин А.В. Адаптивное управление топливоподачей ДВС по показателям неравномерности вращения коленчатого вала. *Вестник Саратовского государственного технического университета*. 2013. № 2(71). С. 80–83.
6. Горлач А.А. Минц М.Я., Чинков В.Н. Цифровая обработка сигналов в измерительной технике. Киев: Техника, 1989. 151 с.
7. Еникеев А.Ф., Борисенко А.Н., Самсонов В.П., Киселева Г.М. Диагностирование дизель-генератора по девиации частоты вращения вала. *Измерительная техника*. 1988. № 9. С. 22–26.
8. Єникеев О.Ф., Монченко О.В., Щербак Т.Л. Метрологічні характеристики перетворювача миттєвої швидкості обертання шліфувального круга при алмазному шліфуванні. *Моделювання та інформаційні технології*. 2012. Вип. 63. С. 42–48.
9. Марченко Б.Г., Мыслович М.В. Теория диагностики энергоагрегатов по девиации вращающихся узлов и ее практическое применение для дизель-электрических генераторов. Часть 1. *Технічна електродинаміка*. 1998. № 5. С. 36–40;
10. Часть 2. *Технічна електродинаміка*. 1998. № 6. С. 39–42;
11. Часть 3. *Технічна електродинаміка*. 1999. № 1. С. 59–63;
12. Часть 4. *Технічна електродинаміка*. 1999. № 4. С. 40–45.
13. Мягков В.Д. Допуски и посадки. Часть 2. Ленинград: Машиностроение, 1978. С. 545–1032.
14. Покусаев М.Н., Сибиряков К.О., Шевченко А.В. Экспериментальное определение степени неравномерности сращения вала машинно-двигательного комплекса судна пр. 1557. *Вестник АГТУ*. 2008. № 2(43). С. 140–144.
15. Полякова Т.А. Решение дифференциальных уравнений свободных и вынужденных крутильных колебаний вала с одной массой. *Вестник СибАДИ*. 2012. Вып. 4(26). С. 90–94.
16. Challen B., Baranescu R. Diesel Engine Reference Book. Butterworth-Heinemann, 1999. 682 p.
17. Gawande S.H., Navale L.G., Nandgaonkar M.R., Butala D.S., Kunamalla S. Cylinder Imbalance Detection of Six Cylinder DI Diesel Engine Using Pressure Variation. *International Journal of Engineering Science and Technology*. 2010. Vol. 2(3). Pp. 433–441.
18. Gawande S.H., Navale L.G., Nandgaonkar M.R., Butala D.S. Harmonic Frequency Analysis of Multi- Cylinder Inline Diesel Engine Genset for Detecting Imbalance. *International Review of Mechanical Engineering*. 2009. Vol. 3. No 6. Pp. 782–787.

Надійшла 20.02.2018

Остаточний варіант 18.02.2019