

TRANSIENT ANALYSIS IN CIRCUITS OF ELECTRIC DISCHARGE INSTALLATIONS WITH VOLTAGE FEEDBACK TAKING INTO ACCOUNT THE RECOVERY TIME OF LOCKING PROPERTIES THEIR SEMICONDUCTOR SWITCHES

A.A. Shcherba*, N.I. Suprunovska**, M.A. Shcherba***
 Institute of Electrodynamics National Academy of Sciences of Ukraine,
 pr. Peremohy, 56, Kyiv, 03057, Ukraine,
 e-mail: iednat1@gmail.com

The paper substantiates the approach to the selection of the inductance value of the choke in the reverse-recharge circuit of a capacitor of thyristor electric discharge installations with controlled voltage feedback (in particular, installations for volumetric electro-spark dispersion of metals in a liquid). The approach is based on taking into account the recovery time of the locking properties of the thyristor in the discharge circuit of such installations, as well as the permissible losses in the reverse-recharge circuit of a capacitor. The results of mathematical modeling of the transient processes in the capacitor circuits of such installations have shown that if the choke inductance is correctly selected in the reverse-recharge circuit of a capacitor, then it is possible to switch on this circuit before the end of the discharge process of the capacitor to the load (i.e., when the capacitor discharge circuit change its configuration during capacitor discharge). In this case, the losses in the reverse-recharge of the capacitor will not exceed 10% of the energy stored in the capacitor before the recharge start. References 10, figures 5, tables 2.

Keywords: transients, capacitor discharge, reverse recharge, thyristor recovery time.

Introduction. Capacitive energy storages (capacitor banks) are most often used in various electric discharge installations, as they can realize the greatest pulsed currents and power in the load in comparison with other storage devices [1–7]. To optimize the operation modes of electric discharge installations with both linear [1–5, 8] and nonlinear [6, 9] capacitors, as well as for the synthesis of new structures of such installations [8, 9], it is important to estimate the ranges their main characteristics variation. Reservoir capacitors are also used in installations for electrical discharge machining of materials [2, 4], in particular, in thyristor installations for volumetric electro-spark dispersion (VESD) of metals in liquid [5, 7]. In such installations, the oscillating charge of the reservoir capacitor from the DC voltage generator (DCVG) and oscillating discharge of this capacitor to the electric spark load, which is a layer of metal granules immersed in the liquid between the electrodes, are usually used [5, 7]. Analysis of the transients in the circuits of such installations is substantially complicated, since the electrical resistance of their load can vary randomly from discharge to discharge [5, 7].

In Fig. 1 the electrical diagram of installation for VESD of metal in a liquid is presented. In the diagram the oscillatory charge of capacitor C is carried out from the DCVG of the voltage U_{DCVG} after unlocking the charging thyristor VT through choke L and resistor R (whose resistance consists of sum of resistances of the DCVG, choke, circuit wires and capacitor). The oscillatory capacitor discharge is performed after unlocking the discharge thyristor VT_1 through spark discharge load with resistance R_{load} and resistor R_1 (discharge circuit resistance) and the choke L_1 (discharge circuit inductance, which is usually 1–5 μH). The use of oscillatory processes of charge and discharge of the capacitor allows to realize fast natural locking of thyristor keys VT and VT_1 and sufficiently high frequency of discharge current pulses (usually more than 1 kHz) in the load. The circuit also provides a circuit of reverse capacitor recharge (C - R_2 - VT_2 - L_2 - C) to a certain voltage U_0 for implementing a controlled (negative or positive) feedback.

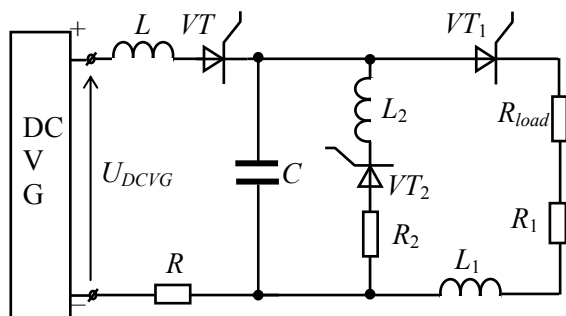

Fig. 1

Using the positive feedback of the capacitor charge voltage U_{ch} with the residual voltage after previous capacitor discharge U_{disch} makes it possible to in-

© Shcherba A.A., Suprunovska N.I., 2018

ORCID ID: * <https://orcid.com/0000-0002-0200-369X> ; ** <https://orcid.com/0000-0001-7499-9142>

*** <http://orcid.org/0000-0001-6616-4567>

crease the voltage U_{ch} and, consequently, the quality factor of the discharge circuit in the subsequent discharge. Such feedback can be used in case of increasing the average statistical resistance of metal granules in the process of their wearing-out between loadings and provides control of such installations modes [5].

A more common practice is the use of a negative feedback of U_{ch} with U_{disch} , which allows to reduce the instability of the discharge modes of installations for VESD of metal at stochastic decrease of the metal granules resistance [5].

In practice, the voltage U_0 is usually not more than 10% of the charge voltage of the capacitor, which makes it possible to use about 80 % of the rated capacity of the capacitor bank.

It should be noted that when a negative feedback U_{ch} with U_{disch} is implement, a special choice of the choke L_2 in the reverse recharge circuit of the capacitor is necessary. On the one hand, the inductance of the choke L_2 is trying to choose a small one in order to increase the frequency of charge-discharge cycles. On the other hand, this inductance should be chosen so that the reverse recharge of capacitor ended after the time required for recovery of locking properties of the discharge thyristor VT_1 . Otherwise, a positive voltage will be applied to the anode of the thyristor VT_1 until the locking properties are restored, which will lead to its re-unlocking. In such a case, weakly damped pulsating currents with a small pulse ratio may appear in the discharge circuit, which can cause an increase in the turn-off time of the switch VT_1 by more than an order of magnitude [5].

Therefore, *the aim of the paper* was to analyze the transients in the reverse recharge circuit of capacitor for selecting the parameters of this circuit, taking into account the recovery time of the locking properties of the thyristor in the discharge circuit of for VESD installations with negative voltage feedback.

Research and discussion of the results. In the analysis of transients in the circuits, it was assumed that the commutation of the thyristor switches occurred instantaneously, while in the closed state their resistance was equal to infinity, and accordingly the current and power dissipation was zero, and in the open state their resistance and the corresponding voltage drop and power dissipation were zero.

The capacitor voltage and the current in the reverse recharge circuit of the capacitor vary according to the expressions [5]

$$u_C(t) = U_{disch} e^{-\omega_{02}t/2Q_2} (\sin \omega_{02}At/2Q_2A + \cos \omega_{02}At), \quad (1)$$

$$i_2(t) = U_{disch} e^{-\omega_{02}t/2Q_2} \sin \omega_{02}At / L_2\omega_{02}A, \quad (2)$$

were U_{disch} – the residual voltage of the capacitor after its previous discharge, which is the initial voltage of its reverse recharge; $Q_2 = \sqrt{L_2} / (\sqrt{C}R_2)$ and $\omega_{02} = \sqrt{1/L_2C}$ – Q -factor and the circular frequency of natural oscillation of the reverse recharge circuit correspondingly; $A = \sqrt{1 - 1/4Q_2^2}$.

To analyze the duration of reverse capacitor recharging, the following parameters of the reverse recharge circuit were set (corresponding to the actual parameters of the installation for producing powders by the method of electro-spark dispersion of metal granules in a liquid) [5]: capacitor capacitance $C = \text{const} = 10^{-4}$ F, the initial voltage of the capacitor reverse recharge $U_{disch} = -300$ V.

The inductance value L_2 should be chosen so that the time, during which the capacitor voltage begins to change its polarity, exceeds the time required to restore the locking properties of the thyristor switch of the discharge circuit VT_1 . According to [10], the locking time of the thyristor taking into account the restoration of its locking properties for thyristors ТБ 353-630-16 (ТБ 353-800-18, ТБ 353-1000-18) used in the installations for VESD is 60 μ s.

When L_2 is changed, the resistance R_2 of the reverse charge circuit, which is basically the resistance of the choke wires of this circuit, also varies depending on the thickness of the wires and the number of its turns. To ensure energy efficiency, it is also necessary that the energy losses during reverse recharge of capacitor do not exceed 10 % of its initial energy.

Calculations and processing of results was carried out using the software package MathCAD 12.

The value of energy losses in the reverse recharge circuit of the capacitor (as a percentage of the energy stored in the capacitor before the start of its reverse recharge) W_{losses} % is given by:

$$W_{losses} \% = \frac{W_{initial} - W_{final}}{W_{initial}} \cdot 100 \% , \quad (3)$$

were $W_{initial} = CU_{initial}^2 / 2$ and $W_{final} = CU_{final}^2 / 2$ – respectively, the energies accumulated in the capacitor before and after its reverse recharge ($U_{initial}$ and U_{final} – respectively the capacitor voltages before and after the reverse recharge process).

Since the reverse recharge circuit has a high Q -factor ($Q_2 \gg 0.5$), then the expression relating the initial and final capacitor recharge voltages can be obtained from (1), taking into account that under this condition the coefficient A can be considered equal to 1, and the time of recharge t_{rech} , is assumed to be equal to the half-period of capacitor reverse recharge ($t_{rech} = \pi\sqrt{L_2C}$)

$$U_{final} = U_{initial} e^{-\omega_{02}t/2Q_2} \left(\sin \omega_{02}\pi\sqrt{L_2C} / 2Q_2 A + \cos \omega_{02}\pi\sqrt{L_2C} \right). \quad (4)$$

Then, taking into account that $\omega_{02} = \sqrt{1/L_2C}$, we get:

$$U_{final} = -U_{initial} e^{-\pi/2Q_2}. \quad (5)$$

After the transformations, the final expression for losses is written as

$$W_{losses} \% = \left(1 - e^{-\pi/2Q_2} \right) \cdot 100 \%. \quad (6)$$

The results of loss calculations at $Q_2 = 20; 25; 30$ are presented in Table 1.

Table 1

Q_2	20	25	30
$W_{losses} \%$	14,5	11,8	9,9

As can be seen from Table 1 the condition that the energy losses during the reverse recharge of the capacitor does not exceed 10% of its initial energy is satisfied only for quality factor of the recharge circuit $Q_2 = 30$.

Figure 2 shows the time dependence of the current in the reverse recharge circuit $i_2(t)$ and the capacitor voltage $u_C(t)$ at $Q_2 = 30$ and different values of L_2 . The results of the analysis of the dependencies in Fig. 2 are given in Table 2. It gives the values of the time of the reverse recharge process until the polarity on the plates of the capacitor changes t_{rech0} (which in oscillatory recharge is determined by the time when the capacitor voltage reaches zero and begins to change its polarity) at $Q_2 = \text{const} = 30$ and various values both inductance L_2 and active resistance R_2 .

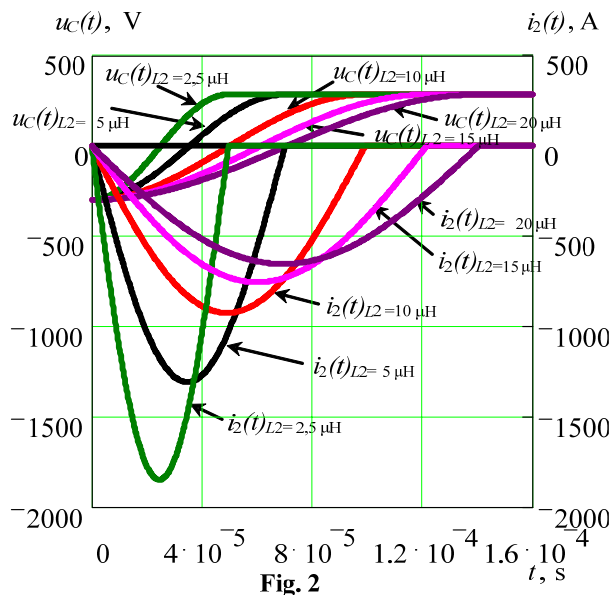

Table 2

$L_2, \mu\text{H}$	2,5	5	10	15	20
R_2, Ω	0,0053	0,0075	0,0105	0,0129	0,0149
$t_{rech0}, \mu\text{s}$	25,1	35,5	50,2	61,5	71,1

Thus, both set conditions: the losses do not exceed 10 % and the time until the capacitor's plates polarity changes exceeds 60 μs (the locking time of the thyristor taking into account the restoration of its locking properties) are satisfied at the following parameters of the reverse recharge circuit: either $L_2 = 15 \mu\text{H}$ and $R_2 = 0.0129 \Omega$ or $L_2 = 20 \mu\text{H}$ and $R_2 = 0.0149 \Omega$ (corresponding to the quality factor of this circuit $Q_2 = 30$).

The numerical simulation has been performed using the MATLAB/SIMULINK/SPS package in

order to consider more complex transients that occur when the reverse recharge circuit $C-R_2-VT_2-L_2-C$ during the discharge of the capacitor to the load, i.e. when the configuration of capacitor discharge circuit was changed during capacitor discharge. The influence of the moment of recharge chain $R_2-VT_2-L_2$ connection (by changing the turn-on time of the thyristor VT_2) on the transients both of the capacitor discharge through the load and subsequent reverse recharge of capacitor was studied.

Figures 3, 4, and 5 show the oscillograms of the voltage and current of the capacitor, as well as the currents in the circuit of its reverse recharge and in the load at following circuit's elements parameters: $U_{DCVG} = 500 \text{ V}$, $C = 10^{-4} \text{ F}$, $L = 2 \cdot 10^{-6} \text{ H}$, $L_1 = 5 \cdot 10^{-6} \text{ H}$, $R = 0.07 \Omega$, $R_{load} = 0.15 \Omega$, $R_2 = 0.015 \Omega$.

Fig. 3 indicates the installation operation, when the connection of $R_2-VT_2-L_2$ recharge chain occurred after capacitor discharge trough the load, and Fig. 4 – in the process of capacitor discharge. The inductance value in the reverse recharge circuit was taken $L_2 = 2 \cdot 10^{-5} \text{ H}$.

Fig. 5 reflects the operation mode in which the recharge chain is connected during the discharge, but the inductance value L_2 is reduced by an order of magnitude ($L_2 = 2 \cdot 10^{-6}$ H). The delay time of the connection of the recharge thyristor VT_2 (relative to start of capacitor charge transient) varied within 0.55–2 ms. The recovery time of the locking properties of the discharge thyristor VT_1 was set equal to $T_{recov} = 0.6$ ms.

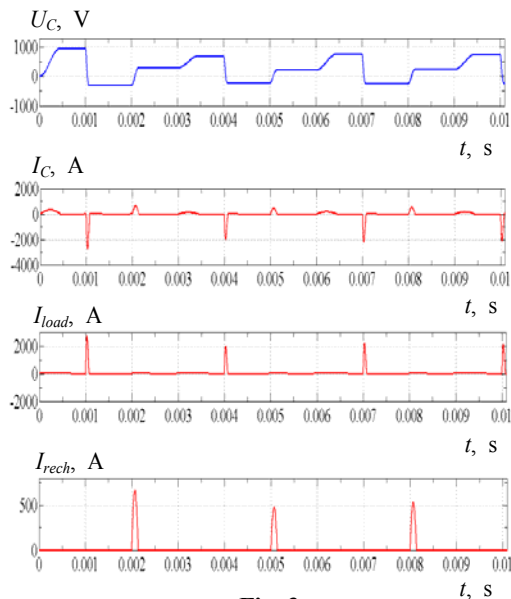

Fig. 3

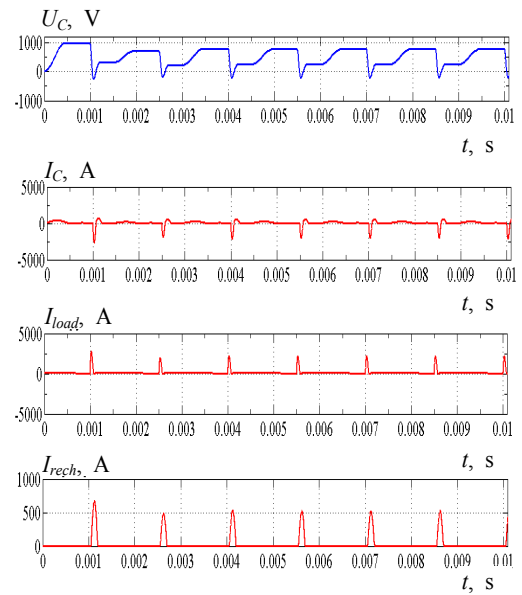

Fig. 4

Analysis of the results in Fig. 3 and 4 showed that if inductance L_2 is properly selected then the stable operation of electric discharge installation could be achieved both when the recharge chain is connected after capacitor discharge and during this discharge. If, however, the value of the inductance L_2 is less than a certain critical value L_{2cr} , which is equal to $2 \cdot 10^{-6}$ H for the circuit in Fig. 1 with parameters $U_{DCVG} = 500$ V, $C = 10^{-4}$ F, $L = 2 \cdot 10^{-6}$ H, $L_1 = 5 \cdot 10^{-6}$ H, $R = 0.07 \Omega$, $R_{load} = 0.15 \Omega$, $R_2 = 0.015 \Omega$, then the capacitor reverse recharge will occur faster than the discharge thyristor VT_1 can restore its locking properties (Fig. 5). In this case, as can be seen from the oscillograms of Fig. 5, the discharge thyristor VT_1 is unlocked again and remains in this state, which will lead to an emergency short circuit mode when the charging thyristor VT is subsequently turned on.

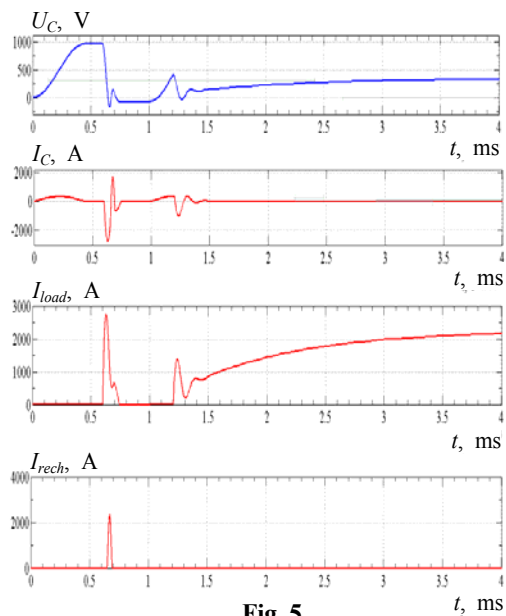

Fig. 5

Conclusion. It is substantiated that for stable trouble-free operation of thyristor electric discharge installations with negative voltage feedback it is necessary to realize two conditions:

- the inductance of the reverse recharge circuit of the capacitor should be selected so that the time for change in capacitor's plates polarity exceeds the time necessary to restore the locking properties of the thyristor in the capacitor discharge circuit;
- the quality factor of the reverse recharge circuit of the capacitor should be such that the energy losses in this circuit is not greater than 10 % of the initial energy of the capacitor.

It is found that both of these conditions are satisfied when Q -factor of reverse recharge circuit of the capacitor is $Q_2 = 30$ and the element's parameters of this circuit is following: either $L_2 = 15 \mu\text{H}$ and $R_2 = 0.0129 \Omega$ or $L_2 = 20 \mu\text{H}$ and $R_2 = 0.0149 \Omega$. In this case, the losses will not greater 10 %, and the pause time between the moments of occurrence on the discharge thyristor the negative (locking) voltage and the positive (unlocking) voltage will not exceed 60 μs (the locking time of thyristors of the type ТБ 353-630-16 that is used in abovementioned installations, taking into account the time of restoration of thyristors locking properties).

1. Livshitz A.L., Otto M.Sh. Pulse electrotechnology. Moskva: Energoatomizdat, 1983. 352 p. (Rus)
2. Mysinski W. Power supply unit for an electric discharge machine. Proc. 13th European Conference on *Power Electronics and Applications EPE'09*. Poznan, Poland, September 01-03, 2009. P. 1–7.
3. Pentegov I.V. Basis of charging circuits of capacitive energy storage. Kyiv: Naukova dumka, 1982. 424 p. (Rus)
4. Sen B., Kiyawat N., Singh P.K., Mitra S., Ye J.H., Purkait P. Developments in electric power supply configurations for electrical-discharge-machining (EDM). Proc. 5th International Conference on *Power Electronics and Drive Systems PEDS2003*. Singapore, 17-20 November 2003. Vol. 1. P. 659–664.
5. Shidlovskii A.K., Shcherba A.A., Suprunovska N.I. Power processes in the electropulse installations with capacitive energy storages. Kiev: Intercontinental-Ukraine, 2009. 208 p. (Rus)
6. Suprunovska N.I., Shcherba A.A., Ivashchenko D.S. Processes of energy exchange between nonlinear and linear links of electric equivalent circuit of supercapacitors. *Tekhnichna Elektrodynamika*. 2015. No 5. P. 3–11. (Rus)
7. Shcherba A.A., Suprunovska N.I., Ivashchenko D.S. Modeling of nonlinear resistance of electro-spark load taking in to account its changes during discharge current flowing in the load and at zero current in it. *Tekhnichna Elektrodynamika*. 2014. No 5. P. 23–25. (Rus)
8. Kravchenko V.I., Petkov A.A. Parametrical synthesis of high-voltage pulse test device with capacitive energy storage. *Electrical engineering & Electromechanics*. 2007. No 6. P. 70–75. (Rus)
9. Vovchenko A.I., Tertilov R.V. Synthesis of capacitive non-linear- parametrical energy sources for discharge-pulse technologies. *Zbirnyk naukovykh pratz Natsionalnoho universytetu korablebuduvannia*. 2010. No 4. P. 118–124. (Rus)
10. Grigorev O.P., Zamiatin V.Ia., Kondratev B.V., Pozhidaiev S.L. Thyristors: handbook. Moskva: Radio i sviaz, 1990. 272 p. (Rus)

УДК 621.3.011

АНАЛІЗ ПЕРЕХІДНИХ ПРОЦЕСІВ У КОЛАХ ЕЛЕКТРОРОЗРЯДНИХ УСТАНОВОК ЗІ ЗВОРОТНИМ ЗВ'ЯЗКОМ ЗА НАПРУГОЮ З УРАХУВАННЯМ ЧАСУ ВІДНОВЛЕННЯ ЗАМИКАЮЧИХ ВЛАСТИВОСТЕЙ ЇХНІХ НАПІВПРОВІДНИКОВИХ КОМУТАТОРІВ

А.А. Щерба, чл.-корр. НАН України, Н.І. Супруновська, докт.техн.наук, М.А.Щерба, канд.техн.наук
 Інститут електродинаміки НАН України,
 пр. Перемоги, 56, Київ, 03057, Україна, e-mail: iednat1@gmail.com

У роботі обґрунтовано підхід до вибору величини індуктивності дроселя в колі зворотного перезаряду конденсатора тиристорних електророзрядних установок з регульованим зворотним зв'язком за напругою (зокрема установок для об'ємного електроіскрового диспергування металів у рідині). Підхід заснований на урахуванні часу відновлення замикаючих властивостей тиристора в розрядному колі таких установок, а також припустимих втрат у колі зворотного перезаряду конденсатора. Результати математичного моделювання перехідних процесів у колах конденсатора таких установок показали, що при правильному виборі величини індуктивності дроселя в колі зворотного перезаряду конденсатора існує можливість включення цього кола до закінчення розрядного процесу конденсатора на навантаження (тобто при зміні конфігурації розрядного кола конденсатора під час його розряду). При цьому втрати під час зворотного перезаряду конденсатора не будуть перевищувати 10 % від енергії, накопиченої в конденсаторі до початку перезаряду. Бібл. 10, рис. 5, табл. 2.

Ключові слова: перехідні процеси, розряд конденсатора, зворотний перезаряд, час відновлення тиристора.

УДК 621.3.011

АНАЛИЗ ПЕРЕХОДНЫХ ПРОЦЕССОВ В ЦЕПЯХ ЭЛЕКТРОРАЗРЯДНЫХ УСТАНОВОК С ОБРАТНОЙ СВЯЗЬЮ ПО НАПРЯЖЕНИЮ С УЧЕТОМ ВРЕМЕНИ ВОССТАНОВЛЕНИЯ ЗАПИРАЮЩИХ СВОЙСТВ ИХ ПОЛУПРОВОДНИКОВЫХ КОММУТАТОРОВ

А.А. Щерба, чл.-корр. НАН Украины, Н.И. Супруновская, докт.техн.наук, М.А.Щерба, канд.техн.наук
 Институт электродинамики НАН Украины,
 пр. Победы, 56, Киев, 03057, Украина, e-mail: iednat1@gmail.com

В работе обоснован подход к выбору величины индуктивности дроселя в цепи обратного перезаряда конденсатора тиристорных электроразрядных установок с регулируемой обратной связью по напряжению (в частности установок для объемного электроискрового диспергирования металлов в жидкости). Подход основан на учете времени восстановления запирающих свойств тиристора в разрядной цепи таких установок, а также допустимых потерь в цепи обратного перезаряда конденсатора. Результаты математического моделирования переходных процессов в цепях конденсатора таких установок показали, что при правильном выборе величины индуктивности дроселя в цепи обратного перезаряда конденсатора существует возможность включения этой цепи до окончания разрядного процесса конденсатора на нагрузку (то есть при изменении конфигурации разрядной цепи конденсатора во время его разряда). При этом потери при обратном перезаряде конденсатора не будут превышать 10 % от энергии, накопленной в конденсаторе до начала перезаряда. Библ. 10, рис. 5, табл. 2.

Ключевые слова: переходные процессы, разряд конденсатора, обратный перезаряд, время восстановления тиристора.

Надійшла 28.11.2017
 Остаточний варіант 01.12.2017