

## MULTIFUNCTIONAL CONVERTER FOR SINGLE-PHASE COMBINED POWER SUPPLY SYSTEMS FOR LOCAL OBJECTS WITH A PHOTOVOLTAIC SOLAR BATTERY

A. Shavelkin, I. Shvedchykova

Kyiv National University of Technologies and Design,  
str. Nemirovich-Danchenko, 2, Kyiv, 01011, Ukraine.

E-mail: [shavolkin@gmail.com](mailto:shavolkin@gmail.com)

*The paper deals with the single-phase converter for combined power supply systems with a built-in transformer and inverter for volt-add, that combines the function of a power active filter with the maintenance of a power factor close to unity when it is operating in parallel with a grid and also the operation in an autonomous mode and voltage stabilization of the load in the normally acceptable range of value. The choice of the circuit parameters is confirmed. It is proposed to use the variable structure of the converter control system with regulation of voltage at the input of a grid inverter in accordance with the value of a grid voltage and cut-off energy generation to the grid when its voltage is higher than the maximum acceptable value. The results of the system simulation are presented. References 4, figures 3.*

**Keywords:** combined power supply system, power active filter, photovoltaic solar battery, current controlled voltage source inverter, transformer and inverter for volt-add, autonomous mode, stabilization of voltage, simulation.

**Introduction.** Currently for local objects (cottage, small enterprise, motel etc.) the combined power supply systems (CPSS) with photovoltaic solar batteries (PVSB) and with connection to AC grid are widely used. In this case the converter of energy, like the PVSB, is used only during the day hours and its power is determined by the maximum power of PVSB, which occurs only during few hours of maximum solar activity in summer. Taking into account the climatic conditions for most of territory of Ukraine the efficiency of such energy installation is low at a sufficiently high cost. Increasing the efficiency of converter system is possible by the accumulation of energy in the battery in day high hours, when PVSB produces maximum energy, with its subsequent transfer to the grid and the load in night time, when PVSB energy generation are reduces. This assumes excess of power PVSB and converter. For local objects with CPSS with two sources (AC grid and PV system) application of rechargeable battery leads to a significant rise in cost of unit. Another way to improve the efficiency of using of CPSS converter is expanding of its functionality. For example, in [1-3] it is proposed to combine the function of the active power filter (APF) with the converter for compensation of inactive power of load at round-the-clock use. The specificity of local objects with CPSS is, as a rule, considerable distance from transformer substations in conditions of existing overloaded, worn out distribution grids use. This causes voltage deviations exceeding the maximum permissible values and with frequent disconnections there are problems in ensuring normal functioning of consumers and the converter unit. Use of converter designed to operate in parallel with an AC grid with wide range of voltage variation [4] reduces efficiency of CPSS. Maintaining of power factor close to unity at point of connection of the object to AC grid will help unloading the grid, reducing energy losses in it and minimization of voltage deviation. In this case is the question of the expediency of energy generation into grid when the voltage increases in it above the permissible value, because it will contribute to growth of a grid voltage. The question of realization an autonomous mode of CPSS operation with a generating energy by PV system when rechargeable battery is absence is also not well developed. Thus, creation of multifunction converters combining the function of APF with round-the-clock use with an integrated unit for stabilization the consumer's voltage and providing an autonomous mode when grid is disconnected during the day is a perspective solution of the problem of increasing of efficiency CPSS with PVSB. In choice of converter structure it is necessary to take into account the change of PV battery voltage depending on temperature for our climatic zone.

**Purpose Statement.** Development of the structure of power circuits and control system of multifunctional single-phase converter of CPSS which combining function of APF with providing an autonomous mode of operation when AC grid is switch-off and function of voltage stabilization of load.

**Main results of research.** In CPSS the converter provides an adjustable power take-off from PVSB and power transmission to AC grid and load and, in this case, APF function. In the structure with DC/DC converter at input of inverter the power take-off function of PV battery performs DC/DC converter. When PVSB is directly connected to grid inverter performs all functions. This solution, by eliminating DC/DC converter, reduces the losses in converter switches. In the climatic conditions of Ukraine, when the change of the  $U_{PV}$  voltage from the temperature can reach at 1.47 times, there is no increase in efficiency (with increasing voltage, the energy losses increase proportionally  $(U_{PV}/U_{ST})^{1.4}$ , where  $U_{ST}$  – value of the voltage for which the switching energy loss is given). In case use of DC/DC is the possibilities of stabilization and control the voltage  $U_d$  at the input of the inverter makes it possible to improve the indicators of the scheme. At the same time solar battery can be collected from solar panels of any power and voltage.

Voltage source inverter (VSI) works in the mode of current controlled voltage source inverter (CCVSI) by the unipolar pulse-width modulation (PWM) with constant frequency  $f_M$  of modulation [2]

$$f_M \geq \frac{a\omega}{8bc}, \quad (1)$$

$$a = 1 + 2 \frac{L}{U_{gm}} \omega I_{CMAXm}, \quad b = \frac{U_L}{U_g} = \frac{\omega L I_{CMAX}}{U_g}, \quad c = \frac{\Delta I_{Cm}}{I_{CMAXm}},$$

where  $L$  – inductance of reactor of CCVSI;  $U_L$  – voltage of the reactor;  $\omega$  – angular frequency of voltage;  $U_g$  – phase voltage of AC grid;  $\Delta I_{Cm}$  – amplitude of current pulsation;  $I_{CMAX}$  and  $I_{CMAXm}$  – accordingly, effective and amplitude values for the maximum value of the inverter's output current.

The voltage  $U_d \geq aU_{gm}$  ( $U_{gm}$  – amplitude of AC voltage) should be selected according to the maximum value of a voltage  $U_g$  of AC grid with the corresponding determination of  $f_M$ . In the case of absence of load at constant power of PVSB and power factor equals one, value of current of CCVSI relatively to nominal value  $U_{gNOM}$  is  $I^* = U_{gNOM}/U_g$ . If the minimum voltage value is, for example,  $U_{gMIN} = 150$  V at a nominal voltage 220 V, then  $I^* = 1,467$ . If the voltage is exceeded – the current decreases. Therefore, the choice of a grid CCVSI switches should be made in accordance with the value of current for  $U_{gMIN}$ . For IGBT class of 1200 V with  $U_{ST} = 600$  V for  $\alpha = 1,3$  the acceptable value is  $U_g = 326$  V.

In the solving the problem of stabilizing of load voltage of local objects we proceed from the following:

- power of PVSB and, correspondingly, of converter is 2 ÷ 2,5 times higher than the load power, which allows to sell excess energy by “green” rate. The volt-add transformer is connected in the load circuit for reducing the power of stabilization circuit;

- a grid inverter work in parallel with AC grid is slave and remains operable over a wide voltage range (for inverter of PVI-5000 (company ABB) 180 ÷ 264 V [4]);

- stabilization is not needed in autonomous mode of operation when AC grid disconnected, in this case, converter ensures the stabilization of consumers' voltage in presence of PV energy generation;

- normally and maximum acceptable values of steady-state deviation of voltage  $\delta U$  at terminals of electrical energy consumer are, accordingly,  $\pm 5$  and  $\pm 10\%$  of rated voltage of the AC grid;

- solution with additional devices use should be integrated as much as possible in converter (sensors, power supplies, etc.) and be compatible in operation with a grid inverter;

- when the voltage rises above the maximum acceptable value, the generation of energy by the converter into the grid is impractical, since this will help increase of the voltage at the connection point to the AC grid. In addition, there will be a useless energy circulation, which is sampled by the stabilizer and through the grid CCVSI again returns to the AC grid. So there is a sense in stopping of the power take off from PVSB. If energy of PVSB is enough for load, it may be expedient to switch the converter into an autonomous mode.

The realization of the autonomous mode when AC grid is switch-off and the rechargeable battery is absent assumes the taking power away from PV system regulated in accordance with the load, as well as the elimination of distortion of load voltage form due nonlinear consumers, which is possible in system that is closed-loop by instantaneous voltage value.

The proposed scheme of converter is shown in Fig. 1 and it contains: AC grid; load, including nonlinear; circuit breakers at converter input  $QF1$  and loads  $QF2$ ;  $R_f C_f$  – filter for suppression of high-frequency current components generated by CCVSI with output reactor  $L1$ ; DC/DC converter for matching voltage of PV system and CCVSI; current CS and voltage VS sensors. In autonomous mode, the converter is disconnected from the grid by means of the contactor  $K$ . The stabilization block contains: transformer  $Tr$ ; additional VSI ( $Q1 \div Q4$ ), which is connected to DC link of CCVSI; reactor  $L2$ ;  $R_{f1} C_{f1}$  – filter that is connected in parallel with the primary winding  $Tr$ .

The power of the transformer is determined by the limiting values deviation of the  $U_g$  and will be maximum

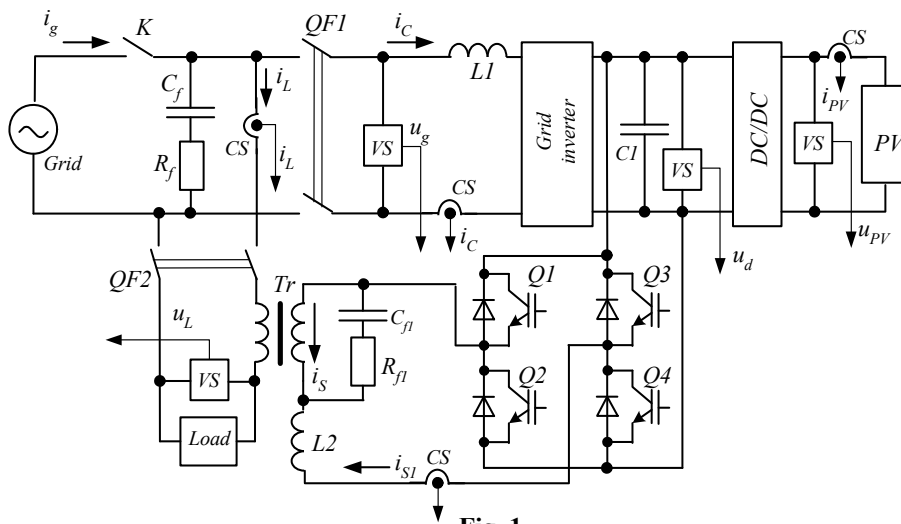

Fig. 1

when the load voltage  $U_L$  is stabilized at a fixed level  $U_{LNOM} = 220$  V. For the case  $U_g = 150 \div 280$  V =  $(0,682 \div 1,272)U_{LNOM}$  the maximum deviation of the  $U_{LNOM}$  is 31.8%. The transformer power will also be 31.8% of the maximum load power. A reduction of the transformer power to 22% can be achieved if the stabilization is performed only when the voltage value  $U_g$  goes beyond  $(220 - \delta U)$  and  $(220 + \delta U)$  (the  $\delta U$  value can be taken at the intermediate level, for example, 7%). In this case, the load voltage takes a

boundary value. If the value of  $u_g$  is within the specified limits that  $u_L = u_g$ .

The structure of control system of converter unit is shown in Fig. 2 and it contains: control block of a grid CCVSI; control block of DC/DC converter; control block of stabilizer inverter (Inverter St). CCVSI control block contains: proportional-integral (PI) voltage controller VC (for work in parallel with AC grid), VC1 (for autonomous mode); current reference block (CREF) of CCVSI; generator of sinusoidal function (GSF) synchronous with a grid voltage; adder (Add), which determines the deviation of inverter current  $\Delta i_C$  relatively to reference value ( $i_{Cref}$ )  $\Delta i_C = i_{Cref} - i_C$ ; current controller (CC) of CCVSI; unit of formation of pulse for control of inverter switches (FI).

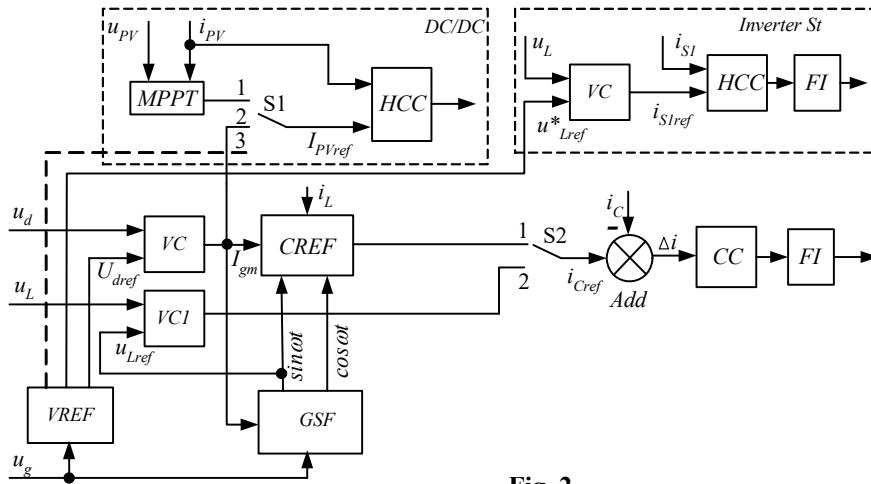

Fig. 2

structure is voltage reference (VREF) block which determines voltage  $U_{dref}$  in the DC link and load voltage  $u^*_{Lref}$  according to voltage of grid  $u_g$ . For this effective value is  $U^*_{Lgref}$

$$U^*_{Lref} = \begin{cases} (U_{NOM} - \delta U), & \text{if } U_g \leq (U_{NOM} - \delta U), \\ (U_{NOM} + \delta U), & \text{if } U_g > (U_{NOM} + \delta U), \\ U_g, & \text{if } (U_{NOM} - \delta U) < U_g < (U_{NOM} + \delta U). \end{cases} \quad (2)$$

VREF also controls by modes of scheme operation. There are following operating modes:

- Operation in parallel with AC grid in the presence and absence of generation of PV energy. For this the switches S1 and S2 are set to position 1. The DC/DC control block takes the maximum power from the PV system. The VC controller, according to the power of PVSb and power of the load, forms the reference value of amplitude of the current of the AC grid  $I_{gm}$ , at which the voltage in the DC link of the converter is equal to  $U_{dref}$ . The reference of current of the CCVSI is generated by the VREF taking into account the reference of the current of the grid  $i_g$ , the load current  $i_L$  and the capacitive filter current.

- Autonomous mode when AC is turn-off. For this the switches S1 and S2 are set to position 2 and reference of current of PV battery determines VC by maintaining the voltage  $U_{dref}$  in DC link at a level that corresponding to nominal voltage of load. VC1 generates the reference value of the CCVSI current. At the VC1 is supplied the reference value of the sinusoidal voltage of load from GSF (from the autonomous generator).

- Operation in parallel with AC grid in the presence of PV generation energy in the case of  $\delta U > 10\%$  with the PV energy consumption ceasing. For this, the switch S1 is set to position 3 (indicated by a dotted line), S2 is set to position 1. VREF sets the minimum value of PV battery current from condition consumption of energy from grid. Another option provided by condition  $P_{SB} > P_{LMAX}$  provides for switching to autonomous mode with disconnection from grid.

**Results of simulation in Matlab.** Matlab software package was used for simulation. Simulation of «AC grid – converter with PVSb – load» system has done for the structure shown on Fig. 1 and Fig. 2 and nonlinear load. The structure of load contains rectifier with output capacitive filter and the RL load with  $\cos\phi = 0,8$ . Model of AC grid (220 V) contains resistance of grid  $R = 0,02$  Ohm,  $X_L = 0,02$  Ohm, filter parameters at the input  $R_f = 0,3$  Ohm,  $C_f = 60$   $\mu$ F. Inductance of the reactor at the output of VSI stabilizer is  $L_2 = 2$  mH, filter parameters at the output are  $R_{f1} = 1$  Ohm,  $C_{f1} = 10$   $\mu$ F. The waveforms of voltage  $u_g$  and current  $i_g$  of AC grid, voltage  $u_L$  and load current  $i_L$ , current of primary winding of transformer  $i_{Tr1}$ , voltage of secondary winding of transformer  $u_{Tr2}$  in parallel operation with AC grid are given: for minimum value of grid voltage ( $U_g = 150$  V),  $U_d = 315$  V,  $n = 3,5$ ,  $U_L = 204$  V (THDu = 0,6%) in the case of generation of PVSb energy with increasing RL load twice at 0,6 s (Fig. 3, a); for the maximum voltage ( $U_g = 280$  V),  $U_d = 515$  V,  $U_L = 235$  V (THDu = 0,54%) and no energy generation of PVSb (Fig. 3, b).

**Conclusions.** The proposed structure of a multifunctional single-phase converter for CPSS with integrated in its structure transformer and inverter for volt-add, when working in parallel with AC grid, provides a combination of

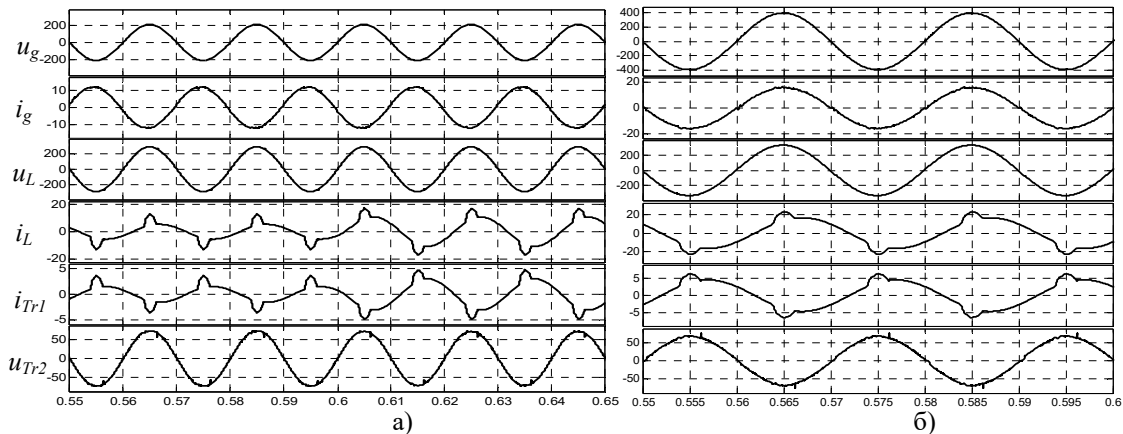

Fig. 3

APF function with round-the-clock maintenance of a power factor close to unity at the point of connection to AC grid and operation in an autonomous mode.

The inverter of stabilization block operates in mode of source of current with the external PI-regulator of voltage, providing support for the voltage value at load within the normally acceptable values according to the voltage of grid. For operation in parallel with AC grid the voltage at input of CCVSI is regulated according to the value of grid voltage. Power generation to AC grid is terminated when AC voltage exceeds the maximum acceptable value. The results of simulation of the system confirm the operability of proposed solutions. Experimental research and practical implementation are the directions of further work.

1. Sung-Hun Ko, Seong-Ryong Lee, Hooman Dehbonei, Nayar C.V. A Grid-Connected Photovoltaic System with Direct Coupled Power Quality Control. 32<sup>nd</sup> Annual Conference on *IEEE Industrial Electronics*, IECON 2006, Paris, France, 6-10 Nov., 2006. Pp. 5203-5208.

2. Tsao-Tsung Ma. Power Quality Enhancement in Micro-grids Using Multifunctional DG Inverters. Proceedings of the International MultiConference of *Engineers and Computer Scientists*, IMECS 2012. Hong Kong, 2012. Vol II. Pp. 996-1001.

3. Shavelkin A.A. Structures of single-phase converters units for combined electrical supply systems with photoelectric solar panels. *Tekhnichna Elektrodynamika*. № 2. 2018. Pp. 39–46. (Rus)

4. ABB solar inverters. [www.abb.com/solarinverters](http://www.abb.com/solarinverters).

УДК 621.314.26

#### БАГАТОФУНКЦІОНАЛЬНИЙ ПЕРЕТВОРЮВАЧ ДЛЯ ОДНОФАЗНИХ КОМБІНОВАНИХ СИСТЕМ ЕЛЕКТРОПОСТАЧАННЯ ЛОКАЛЬНИХ ОБ'ЄКТІВ З ФОТОЕЛЕКТРИЧНИМИ СОНЯЧНИМИ БАТАРЕЯМИ

О.О. Шавьолкін, докт.техн.наук, І.О. Шведчикова, докт.техн.наук

Київський національний університет технологій та дизайну,

вул. Немировича-Данченка, 2, Київ, 01011, Україна.

E-mail: shavolkin@gmail.com

*Розглянуто однофазний перетворювач для комбінованих систем електроживлення з інтегрованими в його структуру вольтододачним трансформатором та інвертором, що забезпечує при роботі паралельно з мережею поєднання функцій силового активного фільтра з підтриманням у точці підключення до мережі близького до одиниці коефіцієнта потужності, роботу в автономному режимі і стабілізацію напруги на навантаженні в нормально допустимих межах. Обґрунтовано вибір параметрів схеми. Запропоновано використання змінної структури системи управління перетворювачем при регулюванні напруги на вході мережевого інвертора відповідно до значення напруги мережі і припинення генерації енергії в мережу, коли її напруга вище гранично допустимого значення. Наведено результати моделювання системи. Бібл. 4, рис. 3.*

**Ключові слова:** комбінована система електроживлення, силовий активний фільтр, фотоелектрична сонячна батарея, мережевий інвертор, вольтододачний трансформатор, автономний режим, стабілізація напруги, моделювання.

УДК 621.314.26

#### МНОГОФУНКЦИОНАЛЬНЫЙ ПРЕОБРАЗОВАТЕЛЬ ДЛЯ ОДНОФАЗНЫХ КОМБИНИРОВАННЫХ СИСТЕМ ЭЛЕКТРОСНАБЖЕНИЯ ЛОКАЛЬНЫХ ОБЪЕКТОВ С ФОТОЭЛЕКТРИЧЕСКИМИ СОЛНЕЧНЫМИ БАТАРЕЯМИ

А.А. Шавьолкин, докт.техн.наук, И.А. Шведчикова, докт.техн.наук

Киевский национальный университет технологий и дизайна,

ул. Немировича-Данченко, 2, Киев, 01011, Украина.

E-mail: shavolkin@gmail.com

*Рассмотрен однофазный преобразователь для комбинированных систем электроснабжения с интегрированными в его структуру вольтодобавочным трансформатором и инвертором, обеспечивающий при работе параллельно с сетью совмещение функции силового активного фильтра с поддержанием в точке подключения к сети близкого к единице коэффициента мощности, работу в автономном режиме и стабилизацию напряжения на нагрузке в нормально допустимых пределах. Обоснован выбор параметров схемы. Предложено использование переменной структуры системы управления преобразователем при регулировании напряжения на входе сетевого инвертора в соответствии со значением напряжения сети и прекращение генерации энергии в сеть, когда ее напряжение выше предельно допустимого значения. Приведены результаты моделирования системы. Библ. 4, рис. 3.*

**Ключевые слова:** комбинированная система электроснабжения, силовой активный фильтр, фотоэлектрическая солнечная батарея, сетевой инвертор, вольтодобавочный трансформатор, автономный режим, стабилизация напряжения, моделирование.

Надійшла 05.03.2018  
Остаточний варіант 11.04.2018